

Transmitter/Receiver photo IC for optical link

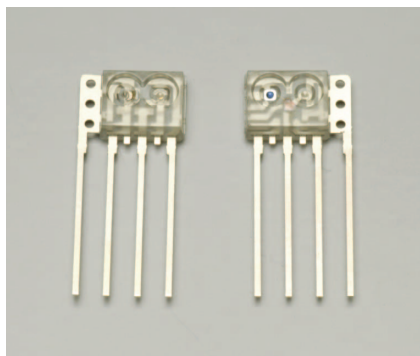

L10663-01, S10664-01

3.3 V operation, for MOST automotive network

The L10663-01 and S10664-01 are transmitter and receiver photo ICs developed for MOST (Media Oriented System Transport) networks used in vehicles to communicate multimedia information. Lower operating voltages in recently manufactured electronic devices have spurred demand for low-voltage and low-current transmitter/receiver photo ICs. To meet this need, HAMAMATSU has been developing low voltage (3.135 V to 3.465 V) photo ICs that still maintain a wide operating temperature range (-40 °C to +105 °C) the same as the conventional types (L10063-01/S10064-01). The transmitter photo IC L10663 consists of a Red-LED and driver IC incorporated into a clear plastic package and can be set to an operating mode that reduces the optical output level by half. The receiver photo IC S10664 features a wide dynamic range. It also has a low power consumption "sleeping mode" and an optical wakeup mode triggered by input of light. Both the transmitter and receiver photo IC input or output digital signals through a TTL interface.

Features

L10663-01

- Wide operating temperature range: -40 to +105 °C
- DC to 50 Mbps data communications
- TTL input
- Optical output 50 % cut mode

S10664-01

- Low current: 24 mA max. (operating mode)
15 µA max. (sleeping mode)
- Wide operating temperature range: -40 to +105 °C
- 4 M to 50 Mbps data communications
- TTL output
- Sleeping mode with optical wakeup

Applications

- Only for vehicle networks (MOST)

MOST compliant products

Specifications of these products are subject to change without prior notice to keep up with changes in the MOST standard.

Absolute maximum ratings*1 (Ta=-40 to +105 °C)

Parameter	Symbol	L10663, S10664	Unit
Supply voltage	Vcc	-0.5 to +7.0	V
Operating temperature	Topr	-40 to +105	°C
Storage temperature	Tstg	-40 to +120	°C
Soldering	Tsol	260 °C, 5 s, 3 times, at least 2.5 mm away from lead root	-

*1: A bypass capacitor (0.1 µF) connected between Vcc and GND at a position within 3 mm from the lead, and a 10 µF capacitor is also connected to the power supply line nearby.

The center of the optical fiber is aligned with the center of the package lens. The distance between the fiber end and the lens top is 0.1 mm.

An external resistor (Rcont) is connected between Cont and -Vcc.

Note: Exceeding the absolute maximum ratings even momentarily may cause a drop in product quality. Always be sure to use the product within the absolute maximum ratings.

L10663-01

Electrical and optical characteristics (Ta=-40 to +105 °C, Vcc= 3.135 to 3.465 V^{*1})

Parameter	Symbol	Condition	Min.	Typ.	Max.	Unit
Current consumption	I _{cc}	V _{in} = 2.0 V, R _{cont} =13.5 kΩ	-	-	40	mA
Peak emission wavelength	λ _p		630	650	670	nm
Spectral half width (FWHM)	Δλ		-	20	30	nm
Fiber coupled optical output 1	Po1	*2 *3 R _{cont} =13.5 kΩ	-9.5	-	-2	dBm
Fiber coupled optical output 2	Po2	*2 *3 R _{cont} =27 kΩ	-13	-	-4.5	dBm
Extinction ratio	re		10	-	-	dB
Rise time at pulse drive	t _r	*2 20 to 80%	-	-	5.5	ns
Fall time at pulse drive	t _f	*2 80 to 20%	-	-	5.5	ns
Pulse width variation	t _{pwv}	*2 *4 50%	19.99	-	24.29	ns
Pulse width distortion (average value)	t _{apwd}	*2 *4 50%	-1.39	-	+1.39	ns

*1: A bypass capacitor (0.1 μF) connected between V_{cc} and GND at a position within 3 mm from the lead, and a 10 μF capacitor is also connected to the power supply line nearby.

The center of the optical fiber is aligned with the center of the package lens. The distance between the fiber end and the lens top is 0.1 mm.

An external resistor (R_{cont}) is connected between Cont and -V_{cc}.

*2: Measured with input signals conforming to SP1 MOST specification of physical layer Rev 1.1 Addendum B

*3: Average value measured with a plastic fiber (φ1 mm, SI-POF, NA=0.5, 1 m) made by Mitsubishi Rayon

*4: Measured with BiPhase PRBS at 45.2 Mbps (NRZ signal conversion)

S10664-01

Electrical and optical characteristics (Ta=-40 to +105 °C, Vcc=3.135 to 3.465 V^{*5})

Parameter	Symbol	Condition	Min.	Typ.	Max.	Unit	
Current consumption (operation mode)	I _{cco}	*6	-	-	24	mA	
Current consumption (sleeping mode)	I _{ccs}	Dark state	-	-	15	μA	
Receiver level	Popt3	Bi-phase signal	-25	-	-2	dBm	
V _{out}	High level output voltage	V _{oh}	I _{oh} = -150 μm	2.5	-	V _{cc} +0.3	V
	Low level output voltage	V _{ol}	I _{ol} =1.0 mA	0	-	0.4	V
	Rise time	t _r	*6 *7 10 to 90%	-	-	9	ns
	Fall time	t _f		-	-	7	
Pulse width variation	t _{pwv}	*6 *7 *8 *9	17.09	-	29.79	ns	
Pulse width distortion (average value)	t _{apwd}	*6 *7 *8 *9	-2.69	-	+6.49	ns	
Operation to sleeping mode transition receivable level	Psl	*6 *10	-39	-	-25.5	dBm	
Sleeping mode to operation transition receivable level	Pop						
Mode output	High level voltage	V _{mh}	I _{mh} =-20 μA	2.5	-	-	V
	Low level voltage	V _{ml}	I _{ml} =0.3 mA	-	-	0.5	V

*5: A bypass capacitor (0.1 μF) is connected between V_{cc} and GND at a position within 3 mm from the lead, and a 10 μF capacitor is also connected to the power supply line nearby.

The center of the optical fiber is aligned with the center of the package lens.

The distance between the fiber end and the lens top is 0.1 mm.

*6: Measured with input signals conforming to SP3 MOST specification of physical layer Rev 1.1 Addendum B

*7: Measured with R_L=50 kΩ, C_L=15 pF (including parasitic capacitance such as probe, connector and evaluation circuit board pattern), and threshold voltage 1.5 V

*8: An optical input waveform is generated with a Hamamatsu standard transmitter.

*9: Measured with BiPhase PRBS at 45.2 Mbps (NRZ signal conversion)

*10: Average optical output is measured with a POF (NA=0.5).

Note: If modulated light at 4 Mbps or less (including DC light and no light input) is input to S10664-01, the high and low levels cannot be discerned.

Mode output waveform (S10664-01)

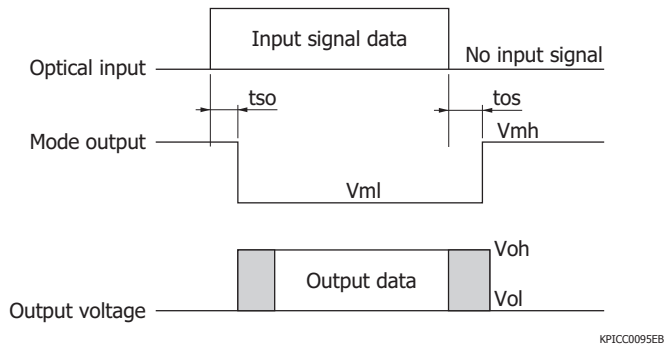

KPIC0095EB

Output waveform example (S10664-01)

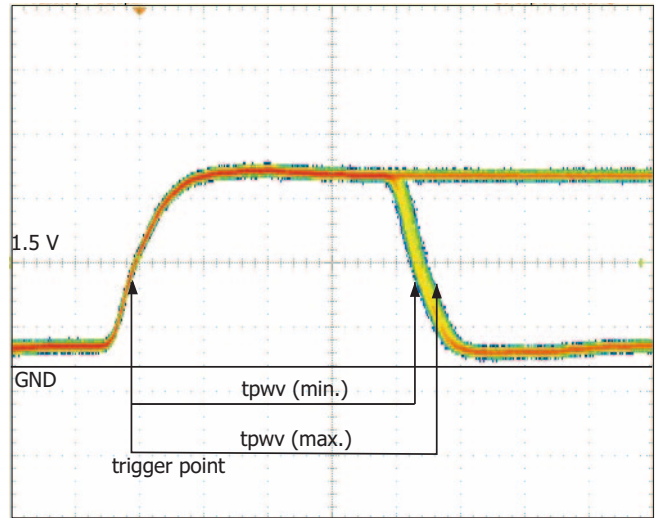

Vertical axis: 1 V/div., Horizontal axis: 5 ns/div.
 (Ta=25 °C, Vcc=3.465 V, Pi=-26 dBm, RL=50 kΩ, CL=15 pF, 45.2 Mbps)

Dimensional outlines (unit: mm)

L10663-01

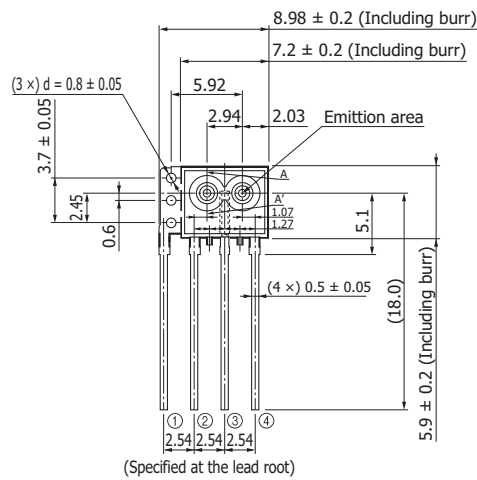

S10664-01

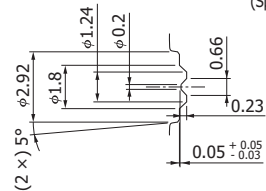
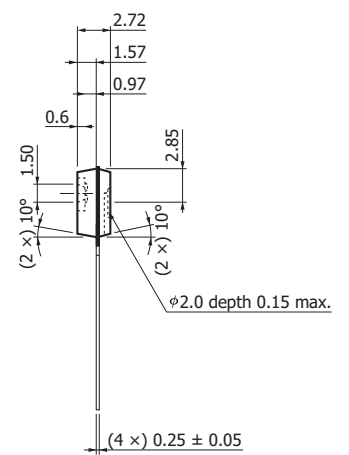
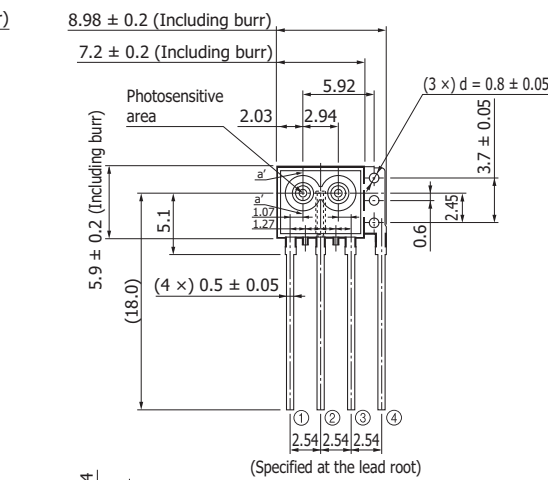

A-A' cross section

Tolerance unless otherwise noted: ±0.1, ±2°
 R0.3 max.
 Values in parentheses indicate reference value.
 Shaded area indicates burr.
 Lead material: Cu alloy with Ni/Pd/Au plating

Pin no.	L10663-01	S10664-01
①	V _{IN}	V _{CC}
②	GND	GND
③	V _{CC}	MODEOUT
④	Cont	V _{OUT}

KPIC0077EB

Related information

www.hamamatsu.com/sp/ssd/doc_en.html

■ Precautions

- Disclaimer
- Metal, ceramic, plastic products

Information described in this material is current as of October 2017.

Product specifications are subject to change without prior notice due to improvements or other reasons. This document has been carefully prepared and the information contained is believed to be accurate. In rare cases, however, there may be inaccuracies such as text errors. Before using these products, always contact us for the delivery specification sheet to check the latest specifications.

The product warranty is valid for one year after delivery and is limited to product repair or replacement for defects discovered and reported to us within that one year period. However, even if within the warranty period we accept absolutely no liability for any loss caused by natural disasters or improper product use. Copying or reprinting the contents described in this material in whole or in part is prohibited without our prior permission.

HAMAMATSU

www.hamamatsu.com

HAMAMATSU PHOTONICS K.K., Solid State Division

1126-1 Ichino-cho, Higashi-ku, Hamamatsu City, 435-8558 Japan, Telephone: (81) 53-434-3311, Fax: (81) 53-434-5184

U.S.A.: Hamamatsu Corporation: 360 Foothill Road, Bridgewater, N.J. 08807, U.S.A., Telephone: (1) 908-231-0960, Fax: (1) 908-231-1218, E-mail: usa@hamamatsu.com

Germany: Hamamatsu Photonics Deutschland GmbH: Arzbergerstr. 10, D-82211 Herrsching am Ammersee, Germany, Telephone: (49) 8152-375-0, Fax: (49) 8152-265-8, E-mail: info@hamamatsu.de

France: Hamamatsu Photonics France S.A.R.L.: 19, Rue du Saule Trapu, Parc du Moulin de Massy, 91882 Massy Cedex, France, Telephone: 33-(1) 69 53 71 00, Fax: 33-(1) 69 53 71 10, E-mail: infos@hamamatsu.fr

United Kingdom: Hamamatsu Photonics UK Limited: 2 Howard Court, 10 Tewin Road, Welwyn Garden City, Hertfordshire AL7 1BW, United Kingdom, Telephone: (44) 1707-294888, Fax: (44) 1707-325777, E-mail: info@hamamatsu.co.uk

North Europe: Hamamatsu Photonics Norden AB: Torshamnsgatan 35 16440 Kista, Sweden, Telephone: (46)8-509 031 00, Fax: (46)8-509 031 01, E-mail: info@hamamatsu.se

Italy: Hamamatsu Photonics Italia S.r.l.: Strada della Moia, 1 int. 6, 20020 Arese (Milano), Italy, Telephone: (39)02-93 58 17 33, Fax: (39)02-93 58 17 41, E-mail: info@hamamatsu.it

China: Hamamatsu Photonics (China) Co., Ltd.: B1201, Jiaming Center, No.27 Dongsanhuan Beilu, Chaoyang District, Beijing 100020, China, Telephone: (86) 10-6586-6006, Fax: (86) 10-6586-2866, E-mail: hpc@hamamatsu.com.cn

Taiwan: Hamamatsu Photonics Taiwan Co., Ltd.: 8F-3, No. 158, Section2, Gongdao 5th Road, East District, Hsinchu, 300, Taiwan R.O.C. Telephone: (886)03-659-0080, Fax: (886)03-659-0081, E-mail: info@tw.hpik.co.jp