



S11106-10

S11107-10

Compact size and high cost-performance

The S11106-10 and S11107-10 are CMOS linear image sensors of resin sealing type that delivers a video data rate of 10 MHz and low current consumption. The pixel size is $63.5 \times 63.5 \mu\text{m}$ (S11106-10), $127 \times 127 \mu\text{m}$ (S11107-10).

Features

- Compact size and high cost-performance
- Resin sealing type, surface mount package: $2.4 \times 9.1 \times 1.6^t$ mm
- Pixel size:
S11106-10: $63.5 \times 63.5 \mu\text{m}$, 128 pixels
S11107-10: $127 \times 127 \mu\text{m}$, 64 pixels
- High-speed data rate: 10 MHz max.
- 3 V or 5 V single power supply operation
- Built-in timing generator allows operation with only Start and Clock pulse inputs
- Low current consumption
- Allows simultaneous charge integration

Applications

- Position detection
- Object measurement
- Rotary encoder
- Image reading

Structure

Parameter	S11106-10	S11107-10	Unit
Number of pixels	128	64	-
Pixel pitch	63.5	127	μm
Pixel height	63.5	127	μm
Photosensitive area length	8.06		mm
Package	Glass epoxy		-
Seal material	Silicone resin		-

Absolute maximum ratings

Parameter	Symbol	Condition	Value	Unit
Supply voltage	V _{dd}	T _a =25 °C	-0.3 to +6	V
Clock pulse voltage	V(CLK)	T _a =25 °C	-0.3 to +6	V
Start pulse voltage	V(ST)	T _a =25 °C	-0.3 to +6	V
Operating temperature*1	T _{opr}		-40 to +85	°C
Storage temperature*1	T _{stg}		-40 to +85	°C
Soldering temperature*2	T _{sol}		260 (3 times)	°C

*1: No dew condensation

When there is a temperature difference between a product and the surrounding area in high humidity environment, dew condensation may occur on the product surface. Dew condensation on the product may cause deterioration in characteristics and reliability.

*2: Reflow soldering, IPC/JEDEC J-STD-020 MSL2a, see P.11

Note: Exceeding the absolute maximum ratings even momentarily may cause a drop in product quality. Always be sure to the product within the absolute maximum ratings.

➤ Recommended terminal voltage (Ta=25 °C)

Parameter		Symbol	Min.	Typ.	Max.	Unit
Supply voltage		Vdd	3.0	-	5.25	V
Clock pulse voltage	High level	V(CLK)	3.0	Vdd	Vdd + 0.25	V
	Low level		0	-	0.4	V
Start pulse voltage	High level	V(ST)	3.0	Vdd	Vdd + 0.25	V
	Low level		0	-	0.4	V

➤ Electrical characteristics (Ta=25 °C)

Parameter	Symbol	S11106-10			S11107-10			Unit	
		Min.	Typ.	Max.	Min.	Typ.	Max.		
Clock pulse frequency	f(CLK)	5 k	-	10 M	5 k	-	10 M	Hz	
Data rate	DR	-	f(CLK)	-	-	f(CLK)	-	Hz	
Output impedance	Zo	60	-	140	60	-	140	Ω	
Current consumption*3	Vdd=3 V	Ic	4.0	6.0	8.0	2.5	4.5	6.5	mA
	Vdd=5 V		7.0	9.0	11.0	4.5	6.5	8.5	

*3: f(CLK)=10 MHz, dark state, V(CLK)=V(ST)=Vdd

➤ Electrical and optical characteristics [Ta=25 °C, Vdd=3 V/5 V, V(CLK)=V(ST)=Vdd, f(CLK)=10 MHz]

Parameter	Symbol	S11106-10			S11107-10			Unit	
		Min.	Typ.	Max.	Min.	Typ.	Max.		
Spectral response range	λ	400 to 1000			400 to 1000			nm	
Peak sensitivity wavelength	λp	-	700	-	-	700	-	nm	
Photosensitivity*4	Sw	-	80	-	-	75	-	V/(lx·s)	
Conversion efficiency*5	CE	-	0.75	-	-	0.35	-	μV/e ⁻	
Output offset voltage	Voffset	0.5	0.8	1.1	0.5	0.8	1.1	V	
Dark output voltage*6	V _D	-	0.02	0.2	-	0.04	0.4	mV	
Saturation output voltage*7	Vdd=3 V	Vsat	1.8	2.0	2.2	1.8	2.0	2.2	V
	Vdd=5 V		3.7	4.0	4.3	3.7	4.0	4.3	
Readout noise*8	Vdd=3 V	Nread	-	1.0	1.5	-	0.9	1.5	mV rms
	Vdd=5 V		-	0.7	1.2	-	0.6	1.1	
Dynamic range 1*9	Vdd=3 V	Drange1	-	2000	-	-	2200	-	times
	Vdd=5 V		-	5700	-	-	6600	-	
Dynamic range 2*10	Vdd=3 V	Drange2	-	100000	-	-	50000	-	times
	Vdd=5 V		-	200000	-	-	100000	-	
Photoresponse nonuniformity*4 *11	PRNU	-	±2	±10	-	±2	±10	%	

*4: Measured with a 2856 K tungsten lamp

*5: Output voltage generated per one electron

*6: Integration time=10 ms

*7: Voltage difference from Voffset

*8: Dark state

*9: Drange1 = Vsat/Nread

*10: Drange2 = Vsat/V_D

*11: Photoresponse nonuniformity (PRNU) is the output nonuniformity that occurs when the entire photosensitive area is uniformly illuminated by light which is 50% of the saturation exposure level. PRNU is measured using 112 pixels (S11106-10) excluding 8 pixels each at both ends or 56 pixels (S11107-10) excluding 4 pixels each at both ends, and is defined as follows:

$$PRNU = \Delta X / X \times 100 [\%]$$

X: the average output of all pixels, ΔX: difference between X and maximum or minimum output

➤ Appearance inspection standards

Parameter	Test criterion	Inspection method
Foreign matter on photosensitive area	10 μm max.	Automated camera

Spectral response (typical example)

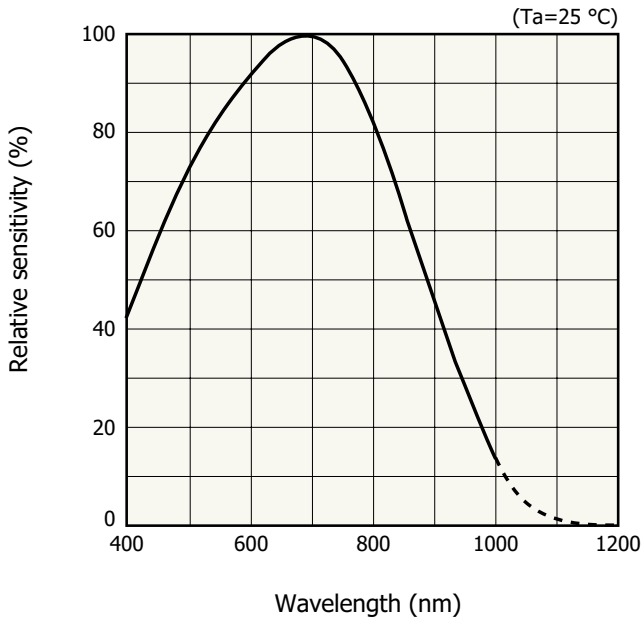

KMPD80347EA

Block diagram

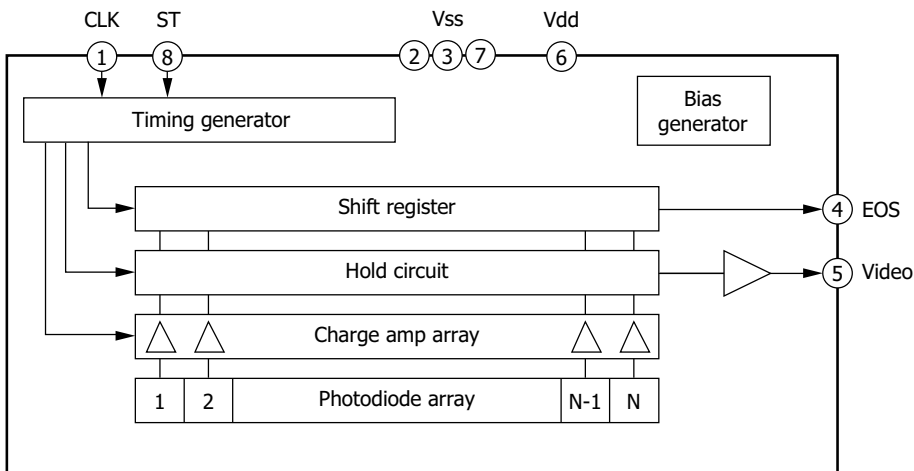

KMPDC0333EB

Output waveform of one pixel

The timing for acquiring the Video signal is synchronized with the rising edge of CLK (See red arrow below).

S11106-10

■ Vdd=3 V

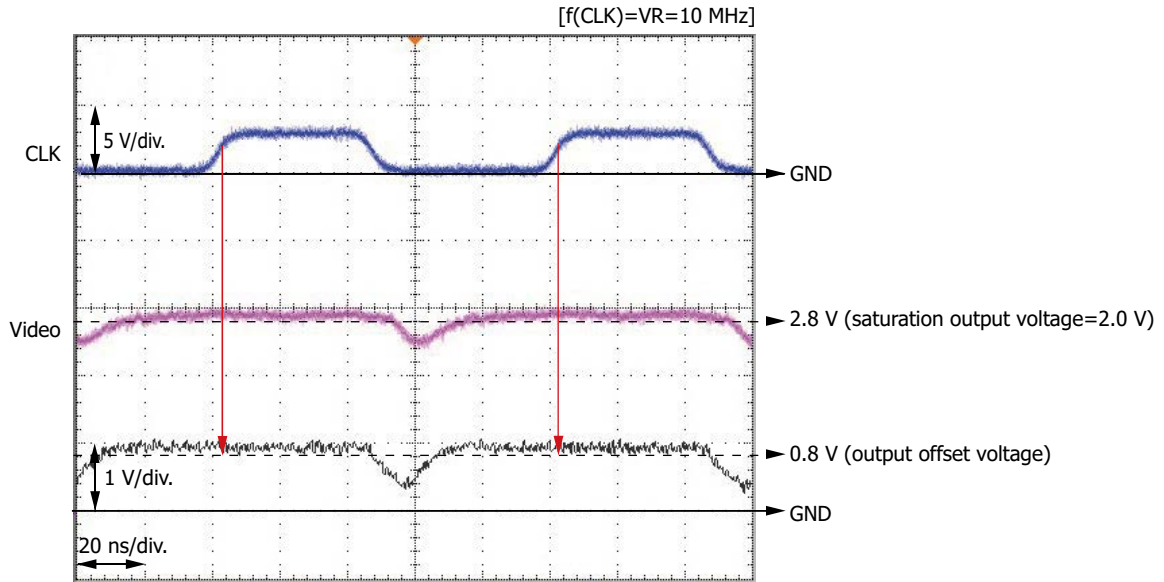

■ Vdd=5 V

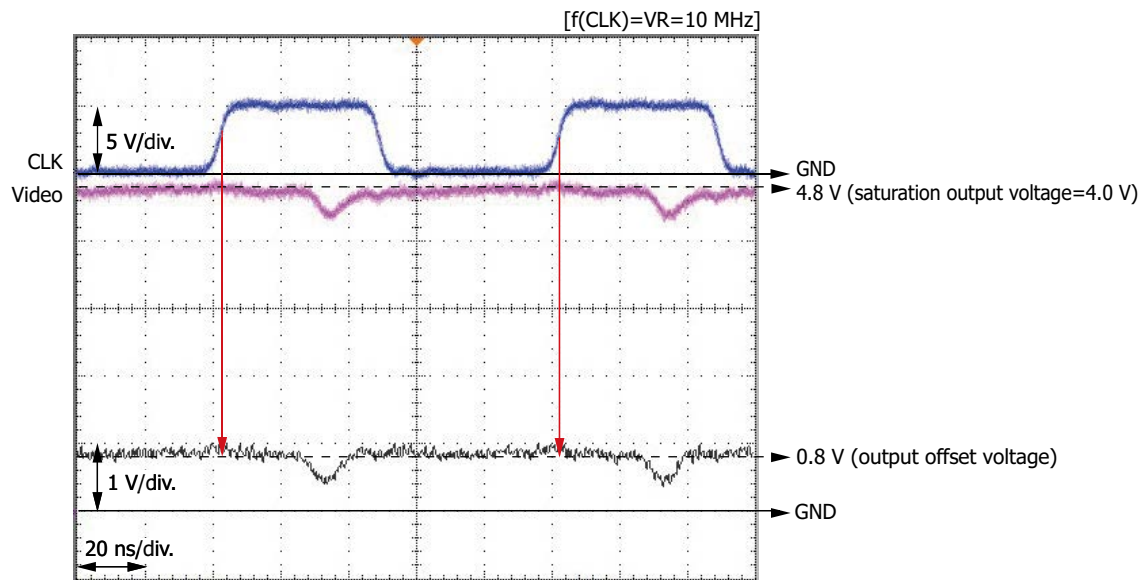

S11107-10

■ Vdd=3 V

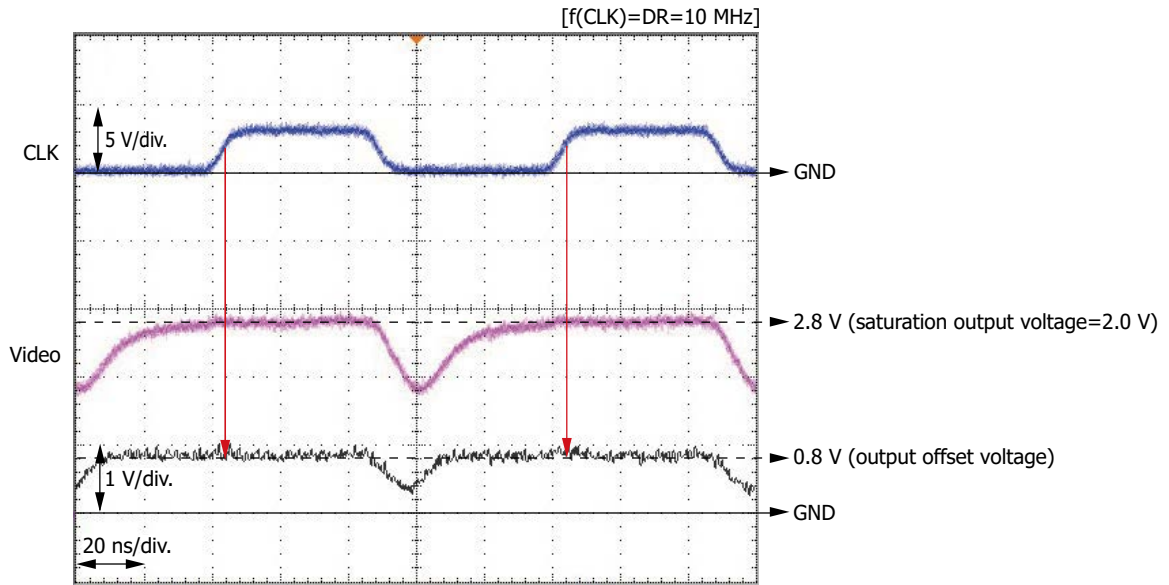

■ Vdd=5 V

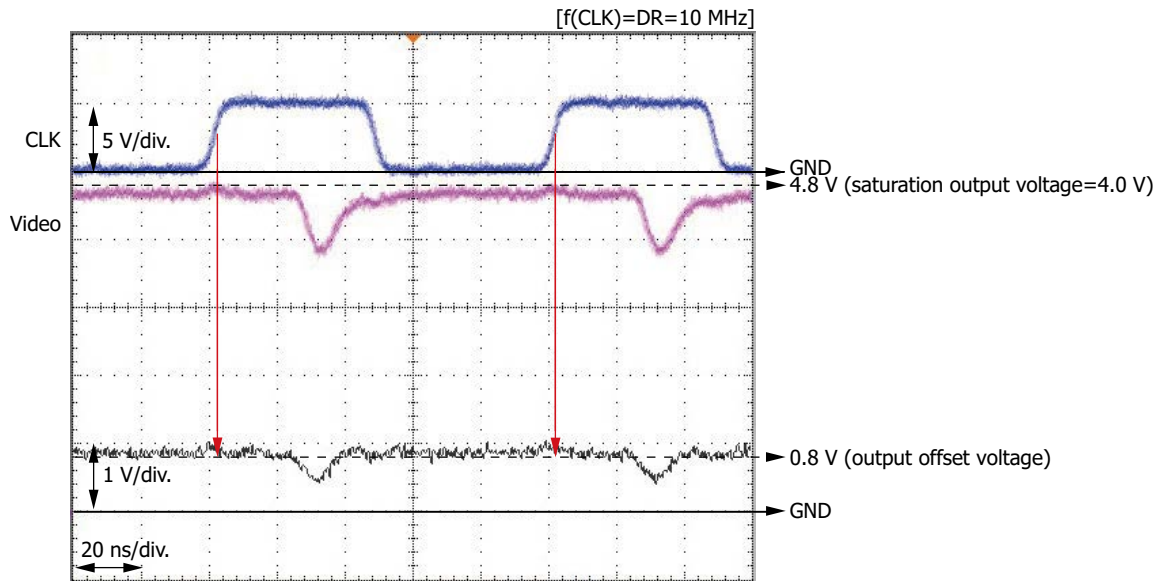

Timing chart

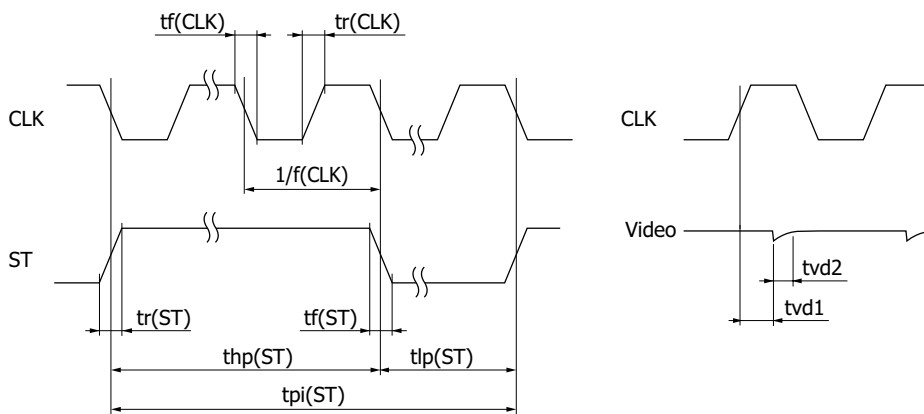
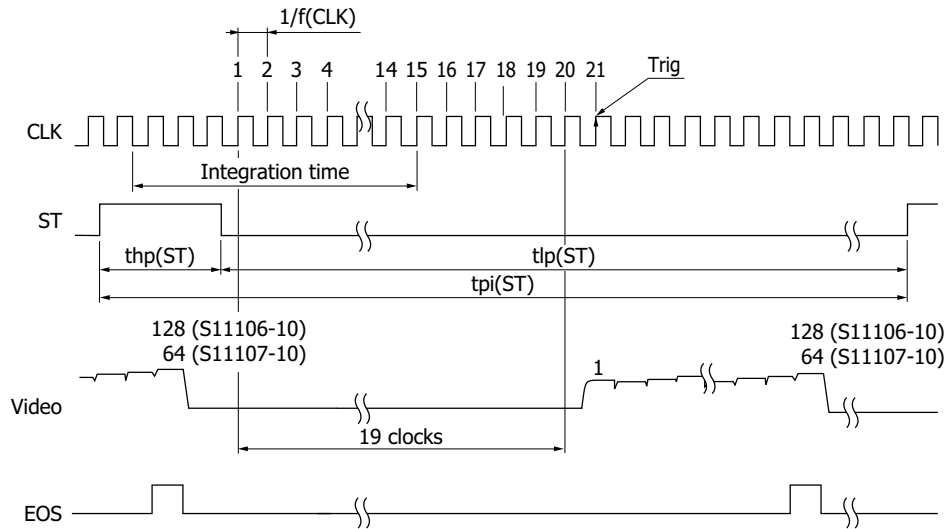

KMPDC0515EB

Parameter	Symbol	S11106-10			S11107-10			Unit	
		Min.	Typ.	Max.	Min.	Typ.	Max.		
Start pulse interval	tpi(ST)	36/f(CLK)	-	-	36/f(CLK)	-	-	s	
Start pulse high period	thp(ST)	4/f(CLK)	-	-	4/f(CLK)	-	-	s	
Start pulse low period	tlp(ST)	32/f(CLK)	-	-	32/f(CLK)	-	-	s	
Start pulse rise and fall times	tr(ST), tf(ST)	0	10	15	0	10	15	ns	
Clock pulse duty ratio	-	45	50	55	45	50	55	%	
Clock pulse rise and fall times	tr(CLK), tf(CLK)	0	10	15	0	10	15	ns	
Video delay time 1*12	tvd1	Vdd=3 V	-	60	-	-	60	-	ns
		Vdd=5 V	-	35	-	-	35	-	
Video delay time 2*12	tvd2	Vdd=3 V	-	35	-	-	35	-	ns
		Vdd=5 V	-	30	-	-	30	-	

*12: Ta=25 °C, CLK=10 MHz, V(CLK)=V(ST)=Vdd

Note: Dark output increases if the start pulse period or the start pulse high period is lengthened.

The internal timing generator starts operation at the rising edge of CLK immediately after ST goes low. The rising edge of this CLK is regarded as "1".

The integration time equals the high period of ST plus 14 CLK cycles and minus 100 ns.

When the ST pulse is set to low while the shift register is operating, the operation of the shift register is reset and the next shift register operation will start.

The integration time can be changed by changing the ratio of the high and low periods of ST.

Operation example

S11106-10

When the clock pulse frequency is maximized (data rate is also maximized), the time of one scan is minimized, and the integration time is maximized (for outputting signals from all 128 pixels)

Clock pulse frequency = Data rate = 10 MHz

Start pulse cycle = $148/f(\text{CLK}) = 148/10 \text{ MHz} = 14.8 \mu\text{s}$

High period of start pulse = Start pulse cycle - Start pulse's low period min.

$$= 148/f(\text{CLK}) - 32/f(\text{CLK}) = 148/10 \text{ MHz} - 32/10 \text{ MHz} = 11.6 \mu\text{s}$$

Integration time is equal to the high period of start pulse + 14 cycles of clock pulses - 100 ns, so it will be $11.6 + 1.4 - 0.1 = 12.9 \mu\text{s}$.

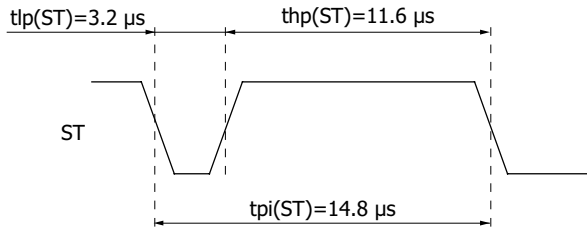

KMPDC0388EB

S11107-10

When the clock pulse frequency is maximized (data rate is also maximized), the time of one scan is minimized, and the integration time is maximized (for outputting signals from all 64 pixels)

Clock pulse frequency = Data rate = 10 MHz

Start pulse cycle = $84/f(\text{CLK}) = 84/10 \text{ MHz} = 8.4 \mu\text{s}$

High period of start pulse = Start pulse cycle - Start pulse's low period min.

$$= 84/f(\text{CLK}) - 32/f(\text{CLK}) = 84/10 \text{ MHz} - 32/10 \text{ MHz} = 5.2 \mu\text{s}$$

Integration time is equal to the high period of start pulse + 14 cycles of clock pulses - 100 ns, so it will be $5.2 + 1.4 - 0.1 = 6.5 \mu\text{s}$.

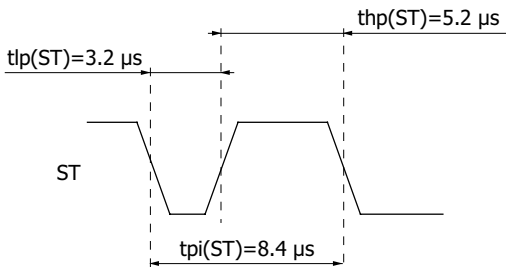

KMPDC0389EB

Dimensional outline (unit: mm)

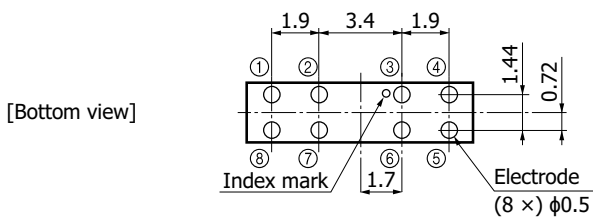
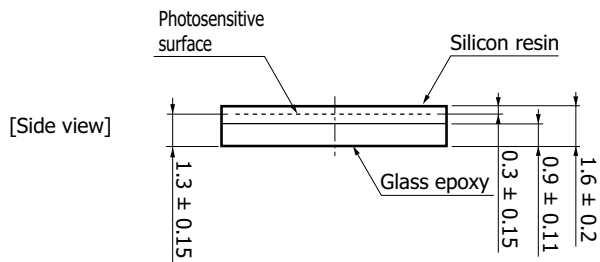
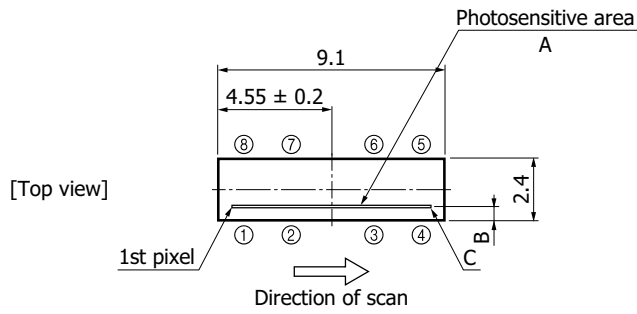

Tolerance unless otherwise noted: ±0.2

Type no.	A	B	C
S11106-10	8.06 × 0.0635	0.4	128 pixels
S11107-10	8.06 × 0.127	0.5	64 pixels

KMPDA0314EB

Pin connections

Pin no.	Symbol	Description	I/O
1	CLK	Clock pulse	I
2	Vss	Ground	-
3	Vss	Ground	-
4	EOS	End of scan	O
5	Video	Video signal	O
6	Vdd	Supply voltage	I
7	Vss	Ground	-
8	ST	Start pulse	I

Recommended land pattern

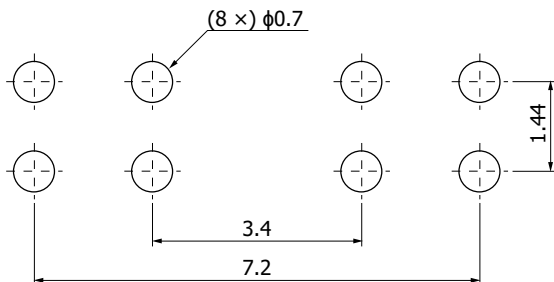

KMPDC0390EA

Details of active area (unit: μm)

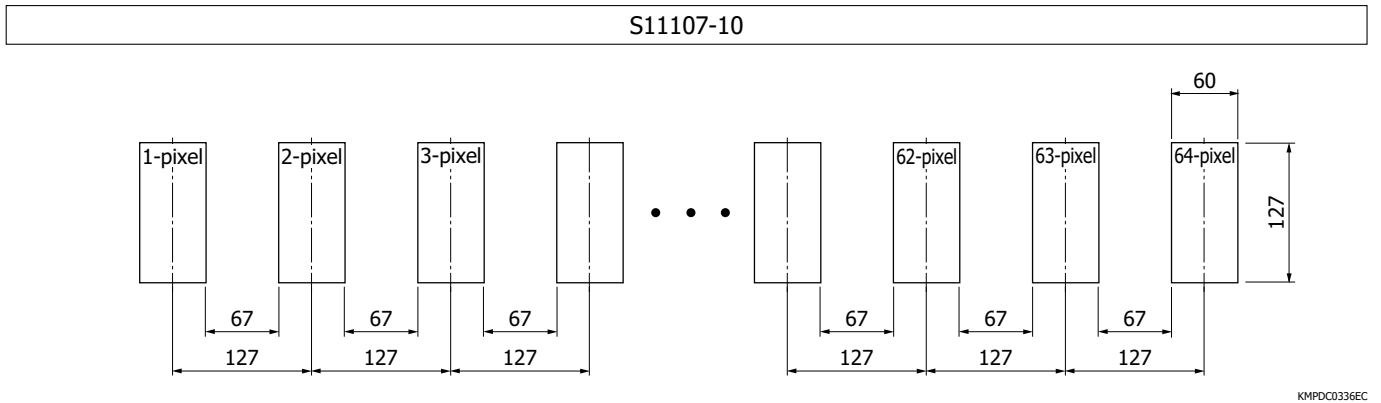
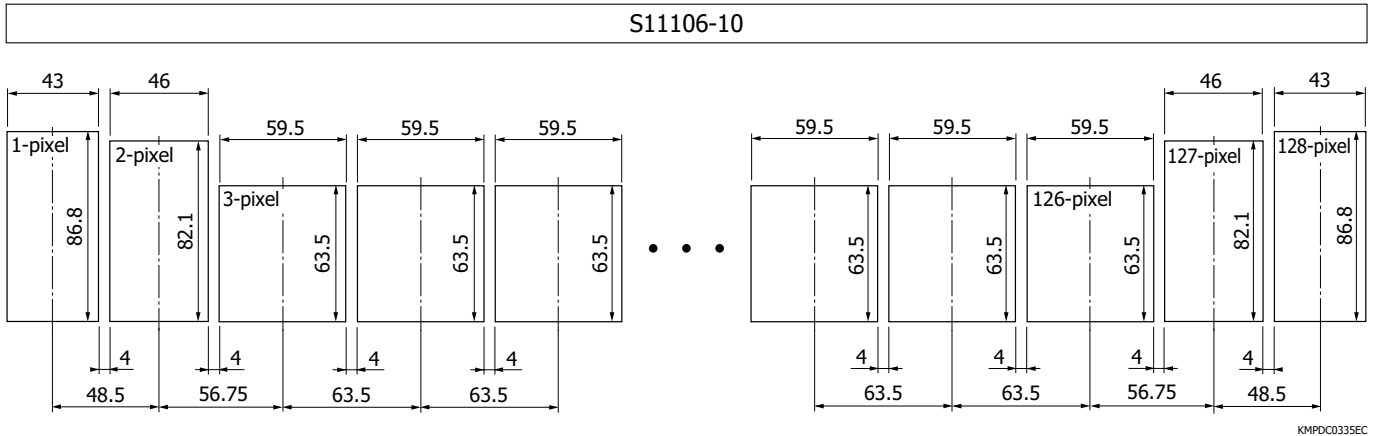

Application circuit example

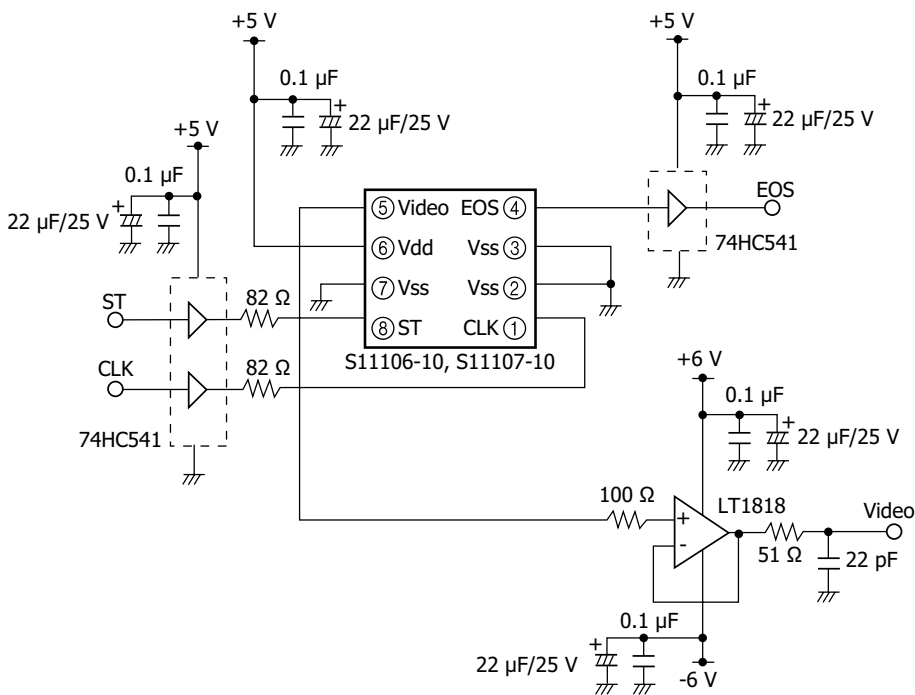

Standard packing specifications

■ Reel (conforms to JEITA ET-7200)

Dimensions	Hub diameter	Tape width	Material	Electrostatic characteristics
330 mm	100 mm	16 mm	PPE	Conductive

■ Embossed (unit: mm, material: polystyrene, conductive)

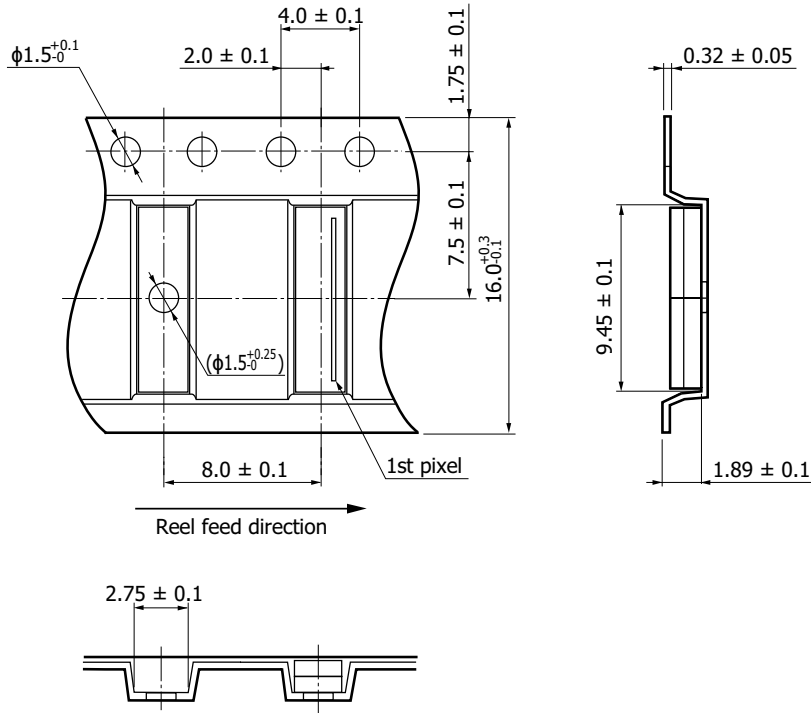

KMPDC0451EA

■ Packing quantity
 2000 pcs/reel
 Packing specifications may vary on orders less than 2000 pieces.

■ Packing type
 Reel and desiccant in moisture-proof packing (vacuum-sealed)

Recommended temperature profile for reflow soldering (typical example)

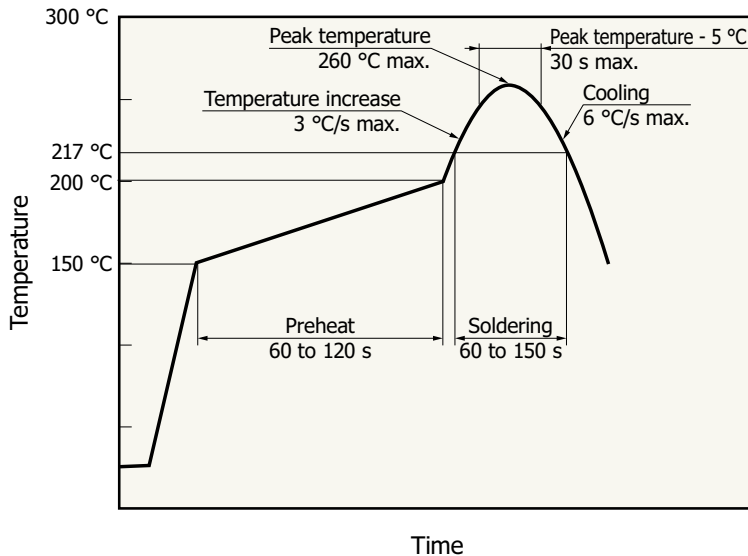

- This product supports lead-free soldering. After unpacking, store it in an environment at a temperature of 30 °C or less and a humidity of 60% or less, and perform soldering within 4 weeks.
- The effect that the product receives during reflow soldering varies depending on the circuit board and reflow oven that are used. Before actual reflow soldering, check for any problems by testing out the reflow soldering methods in advance.
- For the baking method, see the precautions "Resin sealed type CMOS linear image sensors."

Precautions

(1) Electrostatic countermeasures

- This device has a built-in protection circuit as a safeguard against static electrical charges. However, to prevent destroying the device with electrostatic charges, take countermeasures such as grounding yourself, the workbench and tools.
- Protect this device from surge voltages which might be caused by peripheral equipment.

(2) Package handling

- The photosensitive area of this device is sealed and protected by transparent resin. When compared to a glass faceplate, the surface of transparent resin may be less uniform and is more likely to be scratched. Be very careful when handling this device and also when designing the optical systems.
- Dust or grime on the light input window might cause nonuniform sensitivity. To remove dust or grime, blow it off with compressed air.

(3) Surface protective tape

- Protective tape is affixed to the surface of this product to protect the photosensitive area. After assembling the product, remove the tape before use.

(4) Operating and storage environments

- Handle the device within the temperature range specified in the absolute maximum ratings. Operating or storing the device at an excessively high temperature and humidity may cause variations in performance characteristics and must be avoided.

(5) UV exposure

- This product is not designed to prevent deterioration of characteristics caused by UV exposure, so do not expose it to UV light.

Related information

www.hamamatsu.com/sp/ssd/doc_en.html

■ Precautions

- Disclaimer
- Image sensors
- Resin-sealed CMOS linear image sensors

■ Technical information

- CMOS linear image sensors

Information described in this material is current as of October 2024.

Product specifications are subject to change without prior notice due to improvements or other reasons. This document has been carefully prepared and the information contained is believed to be accurate. In rare cases, however, there may be inaccuracies such as text errors. Before using these products, always contact us for the delivery specification sheet to check the latest specifications.

The product warranty is valid for one year after delivery and is limited to product repair or replacement for defects discovered and reported to us within that one year period. However, even if within the warranty period we accept absolutely no liability for any loss caused by natural disasters or improper product use. Copying or reprinting the contents described in this material in whole or in part is prohibited without our prior permission.

HAMAMATSU

www.hamamatsu.com

HAMAMATSU PHOTONICS K.K., Solid State Division

1126-1 Ichino-cho, Chuo-ku, Hamamatsu City, 435-8558 Japan, Telephone: (81)53-434-3311, Fax: (81)53-434-5184

U.S.A.: HAMAMATSU CORPORATION: 360 Foothill Road, Bridgewater, NJ 08807, U.S.A., Telephone: (1)908-231-0960, Fax: (1)908-231-1218

Germany: HAMAMATSU PHOTONICS DEUTSCHLAND GMBH: Arzbergerstr. 10, 82211 Herrsching am Ammersee, Germany, Telephone: (49)8152-375-0, Fax: (49)8152-265-8 E-mail: info@hamamatsu.de

France: HAMAMATSU PHOTONICS FRANCE S.A.R.L.: 19 Rue du Saule Trapu, Parc du Moulin de Massy, 91882 Massy Cedex, France, Telephone: (33)1 69 53 71 00, Fax: (33)1 69 53 71 10 E-mail: infos@hamamatsu.fr

United Kingdom: HAMAMATSU PHOTONICS UK LIMITED: 2 Howard Court, 10 Tewin Road, Welwyn Garden City, Hertfordshire, AL7 1BW, UK, Telephone: (44)1707-294888, Fax: (44)1707-325777 E-mail: info@hamamatsu.co.uk

North Europe: HAMAMATSU PHOTONICS NORDEN AB: Torshamnsgatan 35, 16440 Kista, Sweden, Telephone: (46)8-509-031-00, Fax: (46)8-509-031-01 E-mail: info@hamamatsu.se

Italy: HAMAMATSU PHOTONICS ITALIA S.R.L.: Strada della Moia, 1 int. 6 20044 Arese (Milano), Italy, Telephone: (39)02-93 58 17 33, Fax: (39)02-93 58 17 41 E-mail: info@hamamatsu.it

China: HAMAMATSU PHOTONICS (CHINA) CO., LTD.: 1201, Tower B, Jiaming Center, 27 Dongsanhuan Bellu, Chaoyang District, 100020 Beijing, P.R. China, Telephone: (86)10-6586-6006, Fax: (86)10-6586-2866 E-mail: hpc@hamamatsu.com.cn

Taiwan: HAMAMATSU PHOTONICS TAIWAN CO., LTD.: 13F-1, No.101, Section 2, Gongdao 5th Road, East Dist., Hsinchu City, 300046, Taiwan(R.O.C) Telephone: (886)3-659-0080, Fax: (886)3-659-0081 E-mail: info@hamamatsu.com.tw