

# Photo IC for optical link

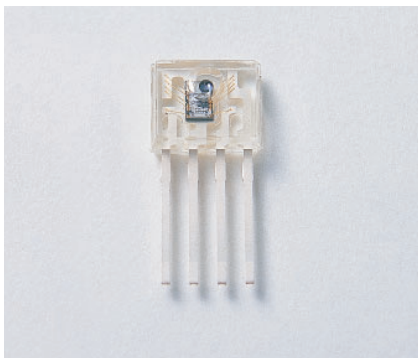

S7727

## Receiver for 156 Mbps POF communications

S7726 is designed for high-speed POF (Plastic Optical Fiber) communications. Both devices are molded into miniature plastic packages with lenses, allowing easy and efficient coupling to a POF. S7727 uses a monolithic photo IC that ensures high resistance to external noise and high reliability, and provides P-ECL voltage conversion output.

### Features

- Photo IC receiver for POF data link
- Monolithic structure immune from external noise
- Data rates from 4 Mbps to 156 Mbps
- P-ECL voltage conversion output  
(Note: Unlike normal P-ECL output, S7727 output cannot be terminated with 50 Ω.)
- Designed to be used with L10881

### Applications

- Plastic optical fiber communications (FA, office machine, home automation, LAN)
- Data transmission in locations subject to high electromagnetic noise

### Absolute maximum ratings

Parameter	Symbol	Condition	Value	Unit
Supply voltage	V <sub>cc</sub>	T <sub>a</sub> =25 °C	-0.5 to +7.0	V
Output voltage	V <sub>o</sub>	T <sub>a</sub> =25 °C	-0.5 to V <sub>cc</sub> + 0.5	V
Output current	I <sub>o</sub>	T <sub>a</sub> =25 °C	8	mA
Power dissipation	P <sub>max</sub>	T <sub>a</sub> =25 °C	250*1	mW
Operating temperature	T <sub>opr</sub>		-20 to +70	°C
Storage temperature	T <sub>stg</sub>		-40 to +85	°C
Soldering	-		230 °C, 5 s, at least 1.5 mm away from package surface	-

\*1: Derate power dissipation at a rate of 1.7 mW/°C above T<sub>a</sub>=25 °C

**Electrical and optical characteristics (Ta=25 °C, Vcc=5.0 V)**

Parameter	Symbol	Condition	Min.	Typ.	Max.	Unit
Data rate	fD	Bi-phase signal NRZ conversion	4	-	156	Mbps
Current consumption	Icc	*2 *3 *6	-	-	40	mA
High level output voltage	Voh	Ioh= -1 mA *2 *3 *6	3.9	-	4.3	V
Low level output voltage	Vol	Iol= -0.5 μA *2 *3 *6	2.9	-	3.4	V
Minimum overload	Pimax	*2 *3 *4 *5 *6	-2	-	-	dBm
Minimum receiver input power	Pimin	*2 *3 *4 *5 *6	-	-	-22	dBm
Rise time	tr	10 to 90% *2 *3 *6	-	-	3	ns
Fall time	tf		-	-	3	ns
Pulse width distortion	ΔT	*2 *3 *4 *6	-3	-	3	ns
Jitter	Δtj	*2 *3 *4 *6	-	-	3	ns

\*2: Measured with 156 Mbps input signal (Bi-phase signal)

\*3: A 3 pF capacitor is connected to GND as a capacitive load (including parasitic capacitance such as probes, connectors and evaluation PCB patterns)

\*4: An optical input waveform is generated with a Hamamatsu standard transmitter.

\*5: A detectable signal level is an average value, measured using a plastic fiber (GH4001 made by Mitsubishi Rayon).

\*6: A 3 kΩ resistor is externally connected between Q and GND and also between QB and GND.

Note)

- A bypass capacitor (0.1 μF) connected at a position within 2 mm from the lead, and a 4.7 μF capacitor is also connected to the power supply line nearby.
- The optical axis of the package lens is exactly aligned with the center axis of the optical plug, and the gap between the lens surface and the optical reference plane of the plug is 0.1 mm.
- If modulated light at 4 Mbps or less (including DC light and no light input) is input to S7727, the high and low levels cannot be discerned.

**Dimensional outline (unit: mm)**

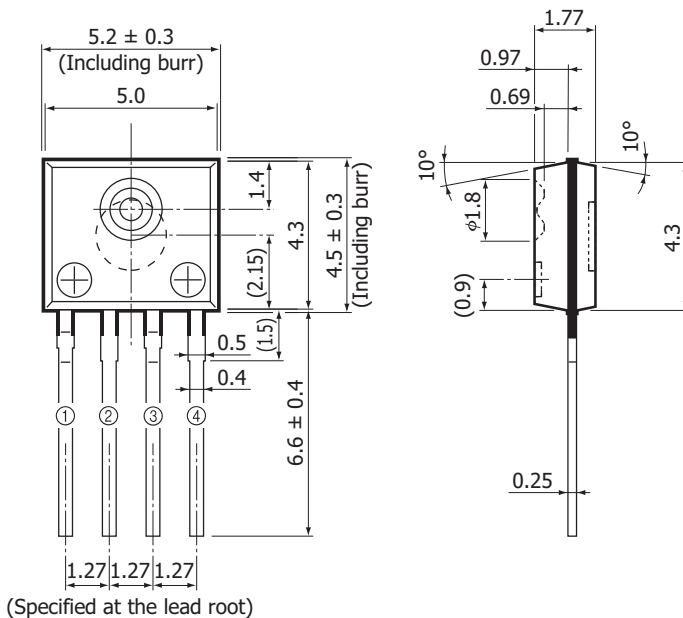

(Specified at the lead root)

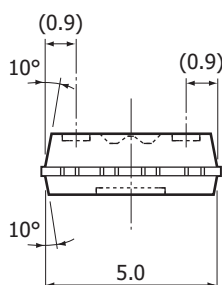

- ① QB
- ② GND
- ③ Q
- ④ Vcc

Tolerance unless otherwise noted: ±0.1, ±2°  
Shaded area indicates burr.  
Values in parentheses indicate reference value.

KPICA0029EC

Information described in this material is current as of December, 2011.

Product specifications are subject to change without prior notice due to improvements or other reasons. Before assembly into final products, please contact us for the delivery specification sheet to check the latest information.

The product warranty is valid for one year after delivery and is limited to product repair or replacement for defects discovered and reported to us within that one year period. However, even if within the warranty period we accept absolutely no liability for any loss caused by natural disasters or improper product use.

Copying or reprinting the contents described in this material in whole or in part is prohibited without our prior permission.

**HAMAMATSU**[www.hamamatsu.com](http://www.hamamatsu.com)

HAMAMATSU PHOTONICS K.K., Solid State Division

1126-1 Ichino-cho, Higashi-ku, Hamamatsu City, 435-8558 Japan, Telephone: (81) 53-434-3311, Fax: (81) 53-434-5184

U.S.A.: Hamamatsu Corporation: 360 Foothill Road, P.O.Box 6910, Bridgewater, N.J. 08807-0910, U.S.A., Telephone: (1) 908-231-0960, Fax: (1) 908-231-1218

Germany: Hamamatsu Photonics Deutschland GmbH: Arzbergerstr. 10, D-82211 Herrsching am Ammersee, Germany, Telephone: (49) 8152-375-0, Fax: (49) 8152-265-8

France: Hamamatsu Photonics France S.A.R.L.: 19, Rue du Saule Trapu, Parc du Moulin de Massy, 91882 Massy Cedex, France, Telephone: 33-(1) 69 53 71 00, Fax: 33-(1) 69 53 71 10

United Kingdom: Hamamatsu Photonics UK Limited: 2 Howard Court, 10 Tewin Road, Welwyn Garden City, Hertfordshire AL7 1BW, United Kingdom, Telephone: (44) 1707-294888, Fax: (44) 1707-325777

North Europe: Hamamatsu Photonics Norden AB: Smidesvägen 12, SE-171 41 Solna, Sweden, Telephone: (46) 8-509-031-00, Fax: (46) 8-509-031-01

Italy: Hamamatsu Photonics Italia S.R.L.: Strada della Moia, 1 int. 6, 20020 Arese, (Milano), Italy, Telephone: (39) 02-935-81-733, Fax: (39) 02-935-81-741

China: Hamamatsu Photonics (China) Co., Ltd.: 1201 Tower B, Jiaming Center, No.27 Dongsanhuan Beilu, Chaoyang District, Beijing 100020, China, Telephone: (86) 10-6586-6006, Fax: (86) 10-6586-2866