

FEATURES

- Spectral response 185 nm to 730 nm
- High cathode sensitivity
 - Luminous 130 $\mu\text{A}/\text{lm}$
 - Radiant at 410 nm 85 mA/W
- High anode sensitivity
 - Luminous 1560 A/lm
 - Radiant at 410 nm $10.2 \times 10^5 \text{ A}/\text{W}$
- Low dark current 0.2 nA
- Low dark counts (R7518P) 10 s^{-1}

APPLICATIONS

- Chemiluminescence detection
- Bioluminescence detection
- Fluorescence spectrometer
- SO₂ monitor (UV fluorescence)



SPECIFICATIONS

GENERAL

Parameter		Description / Value	Unit
Spectral response		185 to 730	nm
Wavelength of maximum response		410	nm
Photocathode	Material	Low noise bialkali	—
	Minimum effective area	8 × 24	mm
Window material		UV glass	—
Dynode	Structure	Circular-cage	—
	Number of stages	9	—
Direct interelectrode capacitances	Anode to last dynode	4	pF
	Anode to all other electrode	6	pF
Base		11-pin base	—
Weight		Approx. 45	g
Operating ambient temperature		-30 to +50	°C
Storage temperature		-30 to +50	°C
Suitable socket		E678-11A (sold separately)	—
Suitable socket assembly		E717-63 (sold separately)	—
		E717-74 (sold separately)	—

Figure 1: Typical spectral response

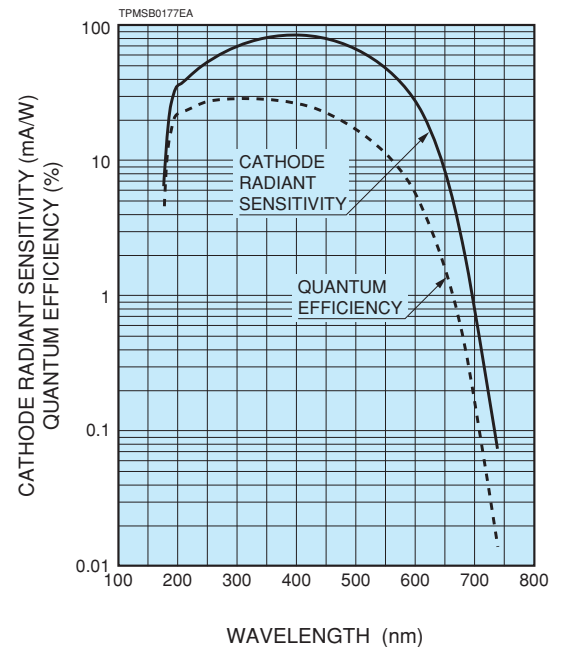

PHOTOMULTIPLIER TUBES

R7518, R7518P (For Photon Counting)

MAXIMUM RATINGS (Absolute maximum values)

Parameter		Value	Unit
Supply voltage	Between anode and cathode	1250	V
	Between anode and last dynode	250	V
Average anode current ^(A)		0.1	mA

CHARACTERISTICS (at 25 °C)

Parameter		R7518 for general purpose			R7518P for photon counting			Unit
		Min.	Typ.	Max.	Min.	Typ.	Max.	
Cathode sensitivity	Quantum efficiency (at peak wavelength)	—	29	—	—	29	—	%
	Luminous ^(B)	120	130	—	120	130	—	μA/lm
	Radiant (at peak wavelength)	—	85	—	—	85	—	mA/W
	Blue sensitivity index (CS 5-58)	—	10	—	—	10	—	—
Anode sensitivity	Luminous ^(C)	1200	1560	—	1200	1560	—	A/lm
	Radiant at 400 nm	—	10.2 × 10 ⁵	—	—	10.2 × 10 ⁵	—	A/W
Gain ^(C)		—	1.2 × 10 ⁷	—	—	1.2 × 10 ⁷	—	—
Anode dark current ^(D) (After 30 min storage in darkness)		—	0.2	2.0	—	0.2	0.5	nA
Anode dark counts ^(E)		—	—	—	—	10	50	s ⁻¹
ENI (Equivalent Noise Input) ^(F)		—	2.7 × 10 ⁻¹⁷	—	—	2.7 × 10 ⁻¹⁷	—	W
Time response ^(D)	Anode pulse rise time ^(G)	—	2.2	—	—	2.2	—	ns
	Electron transit time ^(H)	—	22	—	—	22	—	ns
	Transit time spread (TTS) ^(I)	—	1.2	—	—	1.2	—	ns

NOTES

^(A) Averaged over any interval of 30 seconds maximum.

^(B) The light source is a tungsten filament lamp operated at a distribution temperature of 2856 K. Supply voltage is 100 V between the cathode and all other electrodes connected together as anode.

^(C) Measured with the same light source as Note ^(B) and with the voltage distribution ratio shown in Table 1 below.

Table 1: Voltage distribution ratio

Electrodes	K	Dy1	Dy2	Dy3	Dy4	Dy5	Dy6	Dy7	Dy8	Dy9	P
Distribution ratio	1	1	1	1	1	1	1	1	1	1	1

Supply voltage: 1000 V, K: Cathode, Dy: Dynode, P: Anode

^(D) Measured with the same supply voltage and voltage distribution ratio shown in Table 1.

^(E) Measured at the plateau voltage.

Table 2: Voltage distribution ratio for plateau test

Electrodes	K	Dy1	Dy2	Dy3	Dy4	Dy5	Dy6	Dy7	Dy8	Dy9	P
Distribution ratio	1	1	1	1	1	1	1	1	2	1	1

Supply voltage: Plateau voltage, K: Cathode, Dy: Dynode, P: Anode

^(F) ENI is an indication of the photon-limited signal-to-noise ratio. It refers to the amount of light in watts to produce a signal-to-noise ratio of unity in the output of a photomultiplier tube.

$$ENI = \frac{\sqrt{2q \cdot I_{db} \cdot G \cdot \Delta f}}{S} \quad (W)$$

where q = Electronic charge. (1.60 × 10⁻¹⁹ coulomb)

I_{db} = Anode dark current(after 30 minute storage) in amperes.

G = Gain.

Δf = Bandwidth of the system in hertz. (usually 1 hertz)

S = Anode radiant sensitivity in amperes per watt at the wavelength of peak response

^(G) The rise time is the time for the output pulse to rise from 10 % to 90 % of the peak amplitude when the entire photocathode is illuminated by a delta function light pulse.

^(H) The electron transit time is the interval between the arrival of delta function light pulse at the entrance window of the tube and the time when the anode output reaches the peak amplitude. In measurement, the whole photocathode is illuminated.

^(I) Also called transit time jitter. This is the fluctuation in electron transit time between individual pulses in the signal photoelectron mode, and may be defined as the FWHM of the frequency distribution of electron transit times.

Figure 2: Typical gain and anode dark current

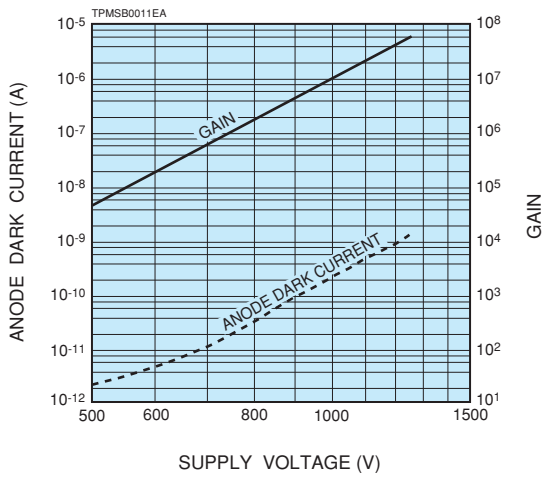

Figure 3: Typical time response

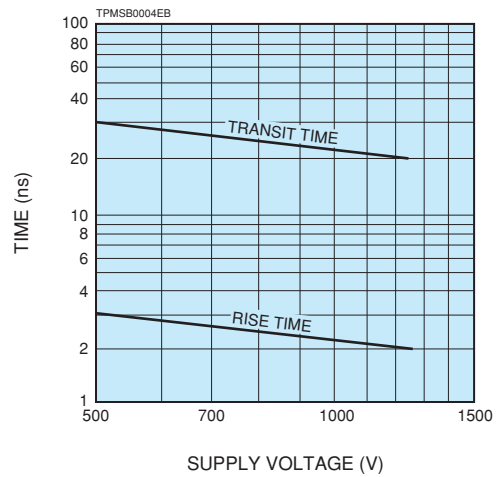

Figure 4: Typical ENI vs. wavelength

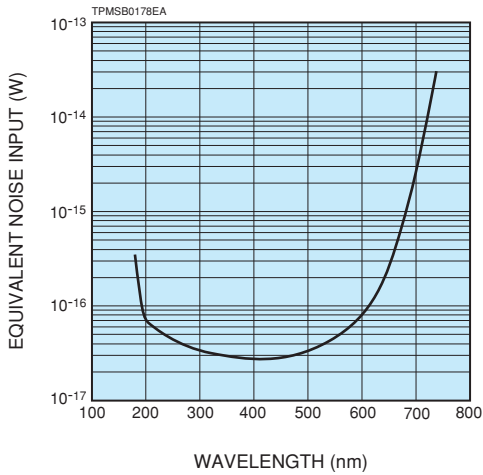
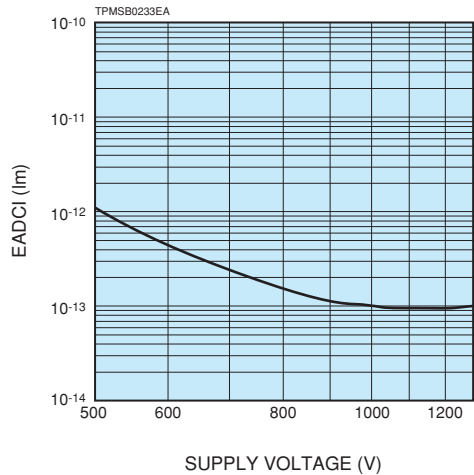

Figure 5: Typical EADCI (Equivalent Anode Dark Current Input) vs. supply voltage



Data shown here, which is given from a relation among supply voltage, anode sensitivity and dark current, serves as a good reference in order to determine the most suitable supply voltage or its range.

Figure 6: Typical plateau data for R7518P

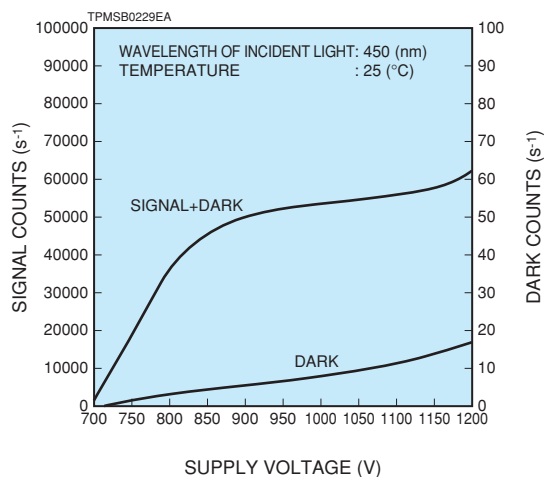
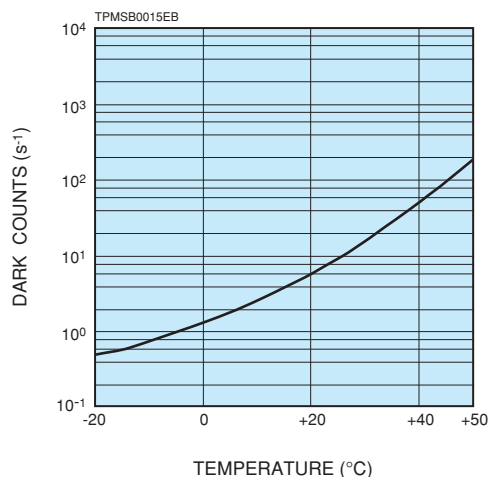
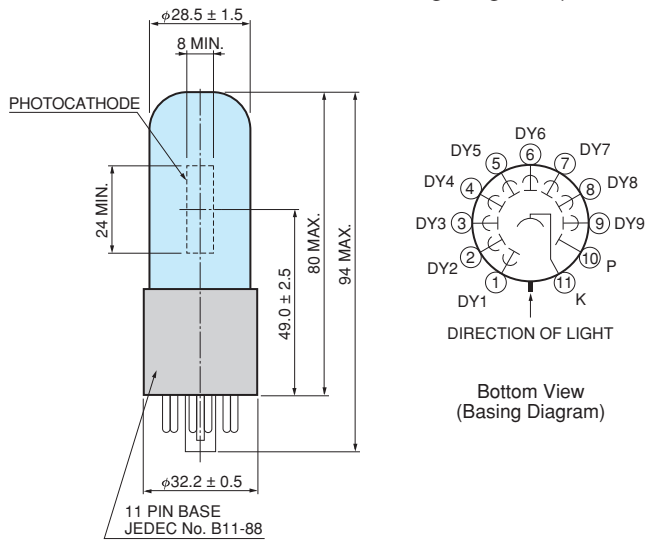

Figure 7: Typical temperature characteristics of dark count for R7518P



PHOTOMULTIPLIER TUBES R7518, R7518P (For Photon Counting)

Figure 7: Dimensional outline and basing diagram (Unit: mm)



TPMSA0001EB

Figure 8: Socket (Unit: mm) **Sold separately**

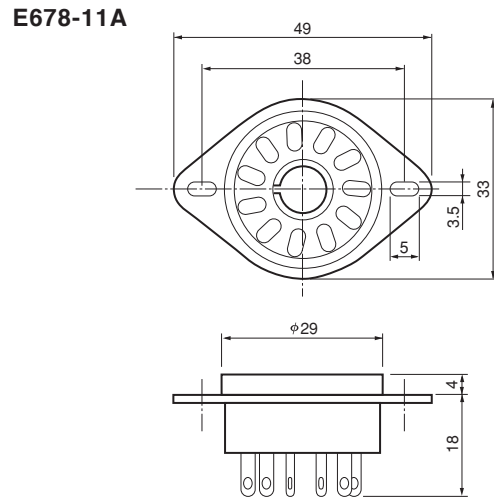

TACCA0064EA

Figure 9: D type socket assembly (Unit: mm) **Sold separately**

E717-63

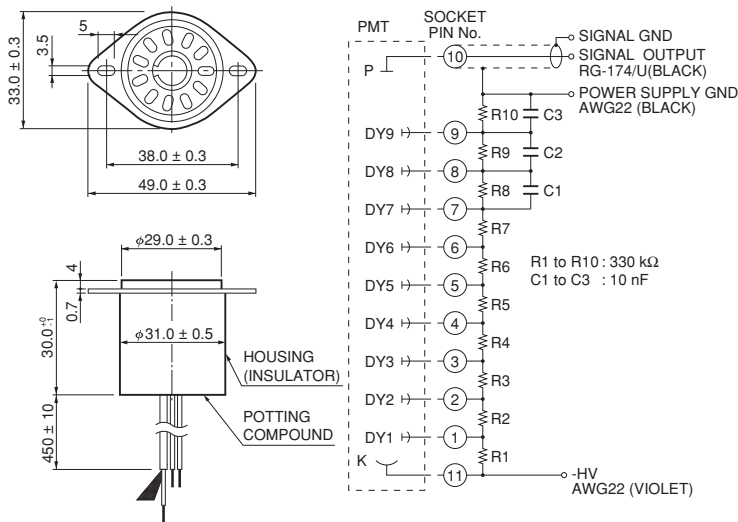

TACCA0002EH

E717-74

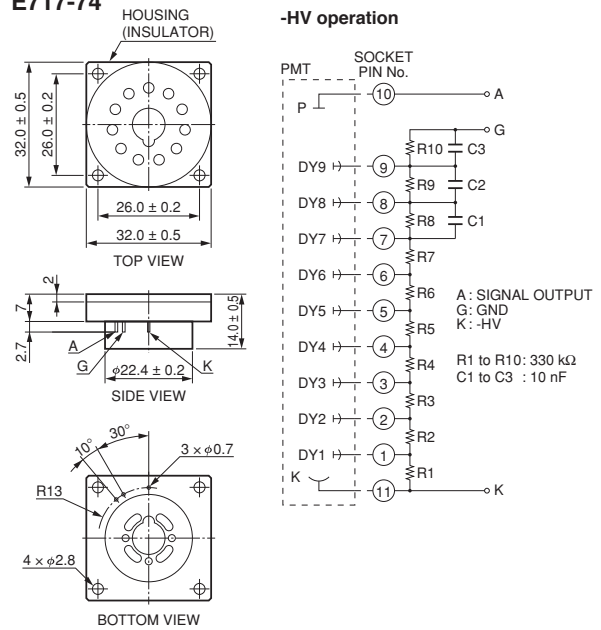

TACCA0277EC

* Hamamatsu also provides C13890 series compact high voltage power supplies and C12597-01, C8991 DP type socket assemblies which incorporate a DC to DC converter type high voltage power supply.

Warning—Personal Safety Hazards

Electrical Shock—Operating voltages applied to this device present a shock hazard.

+HV operation

Cb, Cp and Rp must be connected as follows.

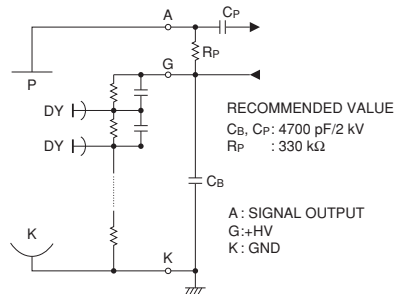

TACCA0343EA

HAMAMATSU PHOTONICS K.K. www.hamamatsu.com

Electron Tube Division

314-5, Shimokanzo, Iwata City, Shizuoka Pref., 438-0193, Japan, Telephone: (81)539/62-5248, Fax: (81)539/62-2205

U.S.A.: HAMAMATSU CORPORATION: 360 Foothill Road, Bridgewater, NJ 08807, U.S.A., Telephone: (1)908-231-0960, Fax: (1)908-231-1218 E-mail: usa@hamamatsu.com

Germany: HAMAMATSU PHOTONICS DEUTSCHLAND GMBH.: Arzbergerstr. 10, 92211 Herrsching am Ammersee, Germany, Telephone: (49)8152-375-0, Fax: (49)8152-265-8 E-mail: info@hamamatsu.de

France: HAMAMATSU PHOTONICS FRANCE S.A.R.L.: 19 Rue du Saule Trapu, Parc du Moulin de Massy, 91882 Massy Cedex, France, Telephone: (33)1 69 53 71 00, Fax: (33)1 69 53 71 10 E-mail: info@hamamatsu.fr

United Kingdom: HAMAMATSU PHOTONICS UK LIMITED: 2 Howard Court, 10 Tewin Road, Welwyn Garden City, Hertfordshire, AL7 1BW, UK, Telephone: (44)1707-294888, Fax: (44)1707-325777 E-mail: info@hamamatsu.co.uk

North Europe: HAMAMATSU PHOTONICS NORDEN AB: Torshamnsgatan 35, 16440 Kista, Sweden, Telephone: (46)8-509-031-00, Fax: (46)8-509-031-01 E-mail: info@hamamatsu.se

Italy: HAMAMATSU PHOTONICS ITALIA S.R.L.: Strada della Moia, 1 int. 6 20044 Arese (Milano), Italy, Telephone: (39)02-93 58 17 33, Fax: (39)02-93 58 17 41 E-mail: info@hamamatsu.it

China: HAMAMATSU PHOTONICS (CHINA) CO., LTD.: 1201, Tower B, Jiaming Center, 27 Dongsanhuan Beilu, Chaoyang District, 100020 Beijing, P.R. China, Telephone: (86)10-6586-6006, Fax: (86)10-6586-2866 E-mail: hpc@hamamatsu.com.cn

Taiwan: HAMAMATSU PHOTONICS TAIWAN CO., LTD.: 13F-1, No.101, Section 2, Gongdao 5th Road, East Dist., Hsinchu City, 300046, Taiwan(R.O.C) Telephone: (866)3-659-0080, Fax: (866)3-659-0081 E-mail: info@hamamatsu.com.tw

TPMS1060E04
AUG. 2023 1P