

■ **Features**

- 3 stack PLD
- Peak output power:  $\geq 100$  W
- Peak emission wavelength: 905 nm
- Emitting area size:  $360 \mu\text{m} \times 10 \mu\text{m}$

■ **Applications**

- Laser range finder
- Security
- Measuring instruments

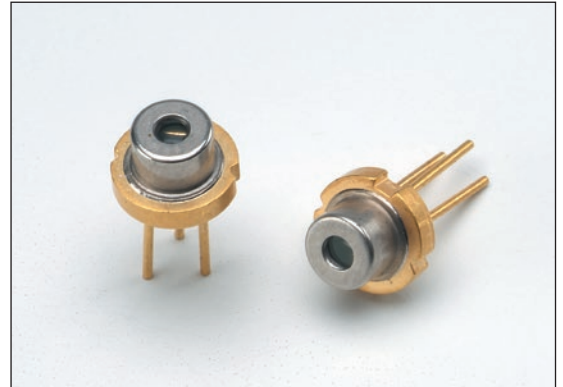

■ **Absolute maximum ratings ( $T_{\text{op}(c)} = 25 \text{ }^\circ\text{C}$ )**

Parameter	Symbol	Value	Unit
Pulsed forward current	$I_{\text{fp}}$	40	A
Reverse voltage	$V_{\text{r}}$	2.5	V
Pulse duration	$t_{\text{w}}$	100	ns
Duty ratio	DR	0.1	%
Operating temperature	$T_{\text{op}(c)}$	-40 to +85	$^\circ\text{C}$
Storage temperature	$T_{\text{stg}}$	-40 to +100	$^\circ\text{C}$

■ **Characteristics ( $T_{\text{op}(c)} = 25 \text{ }^\circ\text{C}$ )**

Parameter	Symbol	Conditions	Value			Unit
			Min.	Typ.	Max.	
Pulsed radiant power (Peak power)	$\Phi_{\text{ep}}$	$I_{\text{fp}} = 35 \text{ A}$	80	100	—	W
Peak emission wavelength	$\lambda_{\text{p}}$		895	905	915	nm
Forward voltage	$V_{\text{op}}$		—	12	15	V
Spectral radiation half bandwidth	$\Delta\lambda$		—	6	10	nm
Rise time	$t_{\text{r}}$		—	—	2	ns
Beam spread angle	Horizontal	$I_{\text{fp}} = 35 \text{ A}$ FWHM	4	8	12	degree
	Vertical		$\theta_{\perp}$	19	24	
Lasing threshold current	$I_{\text{th}}$	—	—	0.8	1.2	A
Emitting area size	—	Value at designing	—	$360 \times 10$	—	$\mu\text{m} \times \mu\text{m}$

Note: General operating condition: pulse width  $t_{\text{w}} = 50 \text{ ns}$ , repetition frequency  $f_{\text{r}} = 1 \text{ kHz}$

# Pulsed Laser Diode L11854-336-05

Figure 1: Radiant flux vs. Forward current (Typ.)

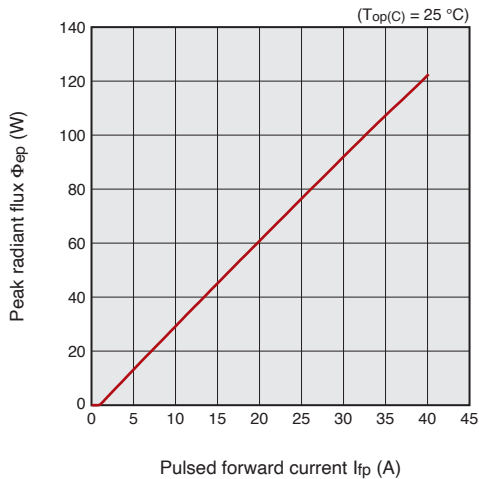

Figure 2: Emission spectrum (Typ.)

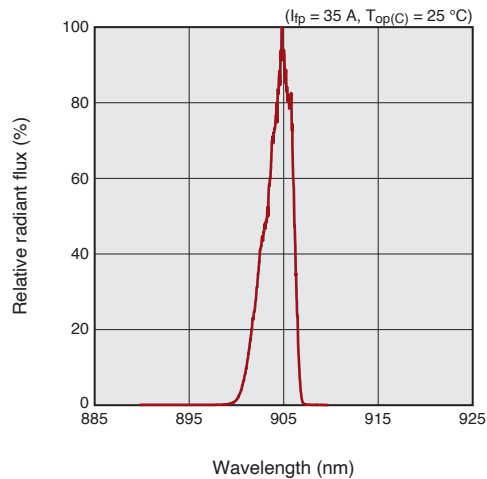

Figure 3: Directivity (Typ.)

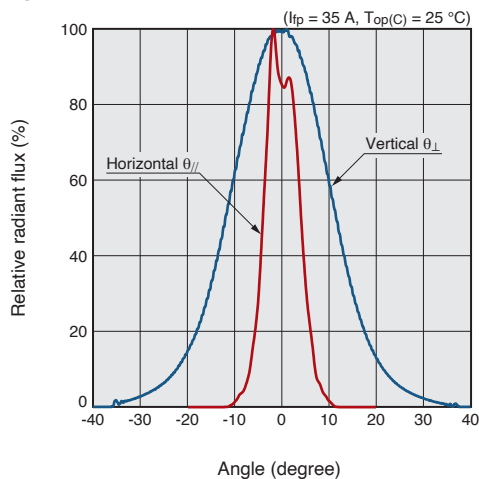

Figure 4: Emitting image of near filed pattern (NFP)

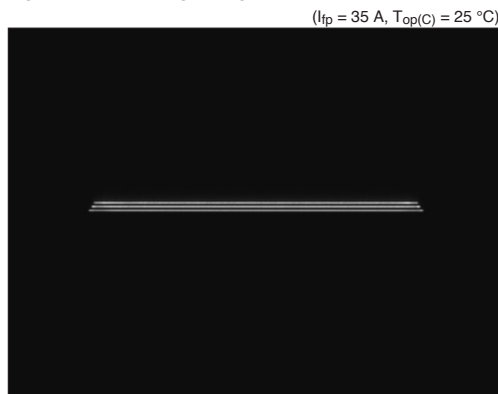
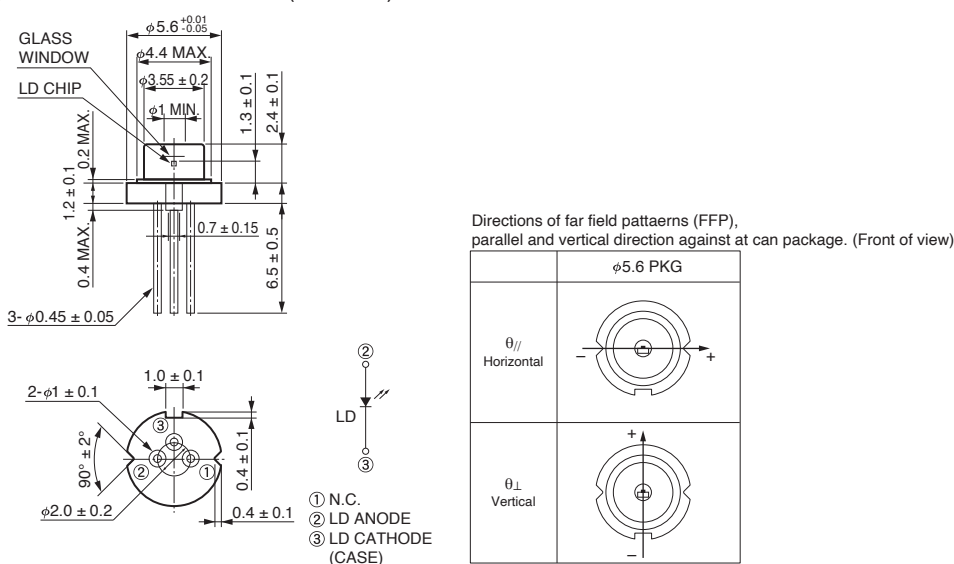

Figure 5: Dimensional outline (unit: mm)



Information described in this material current as of October 2023. Specifications are subject to change without notice.

**HAMAMATSU PHOTONICS K.K.** [www.hamamatsu.com](http://www.hamamatsu.com)

**HAMAMATSU PHOTONICS K.K., Solid State Division**  
 1126-1 Ichino-cho, Higashi-ku, Hamamatsu City, 435-8558 Japan, Telephone: (81)53-434-3311, Fax: (81)53-434-5184

U.S.A.: HAMAMATSU CORPORATION: 360 Foothill Road, Bridgewater, NJ 08807, U.S.A., Telephone: (1)908-231-0960, Fax: (1)908-231-1218 E-mail: usa@hamamatsu.com  
 Germany: HAMAMATSU PHOTONICS DEUTSCHLAND GMBH.: Arzbergerstr. 10, 82211 Herrsching am Ammersee, Germany, Telephone: (49)8152-375-0, Fax: (49)8152-265-8 E-mail: info@hamamatsu.de  
 France: HAMAMATSU PHOTONICS FRANCE S.A.R.L.: 19 Rue du Saule Trapu, Parc du Moulin de Massy, 91882 Massy Cedex, France, Telephone: (33)1 69 53 71 00, Fax: (33)1 69 53 71 10 E-mail: info@hamamatsu.fr  
 United Kingdom: HAMAMATSU PHOTONICS UK LIMITED: 2 Howard Court, 10 Tewin Road, Welwyn Garden City, Hertfordshire, AL7 1BW, UK, Telephone: (44)1707-294888, Fax: (44)1707-325777 E-mail: info@hamamatsu.co.uk  
 North Europe: HAMAMATSU PHOTONICS NORDEN AB: Torshamnsgatan 35, 16440 Kista, Sweden, Telephone: (46)8-509-031-00, Fax: (46)8-509-031-01 E-mail: info@hamamatsu.se  
 Italy: HAMAMATSU PHOTONICS ITALIA S.R.L.: Strada della Moia, 1 int. 6 20044 Arese (Milano), Italy, Telephone: (39)02-93 58 17 33, Fax: (39)02-93 58 17 41 E-mail: info@hamamatsu.it  
 China: HAMAMATSU PHOTONICS (CHINA) CO., LTD.: 1201, Tower B, Jiaming Center, 27 Dongsanhuan Beilu, Chaoyang District, 100020 Beijing, P.R. China, Telephone: (86)10-6586-6006, Fax: (86)10-6586-2866 E-mail: hpc@hamamatsu.com.cn  
 Taiwan: HAMAMATSU PHOTONICS TAIWAN CO., LTD.: 13F-1, No.101, Section 2, Gongdao 5th Road, East Dist., Hsinchu City, 300046, Taiwan (R.O.C) Telephone: (886)3-659-0080, Fax: (886)3-659-0081 E-mail: info@hamamatsu.com.tw