

# Driver circuit for CCD linear image sensor



C11160

## For CCD image sensor (S11151-2048)

The C11160 is a driver circuit designed for Hamamatsu CCD image sensor S11151-2048. The C11160 can be used in spectrometers when combined with the S11151-2048.

The C11160 holds a CCD driver circuit, analog video signal processing circuit (16-bit A/D converter), timing generator, control circuit and power supply. The C11160 converts analog video signals from a CCD into digital signals and outputs them. The USB connector (USB 2.0) provided as a standard feature easily connects to a PC for the C11160 control and data acquisition. The C11160 also has a BNC connector for external trigger input and pulse output. The C11160 is compact, lightweight and very easy to handle.

This product comes with application software (DCam-USB) that runs on Microsoft® Windows® 10 (64-bit). It can be used to easily operate the C11160 from the PC. This product also includes DLLs that the user can use to create original control programs.

### Features

- Built-in 16-bit A/D converter
- Adjustable offset
- Adjustable gain
- Interface of computer: **USB 2.0**
- Power supply: **USB bus power**

Note) Microsoft and Windows are either registered trademarks or trademarks of Microsoft Corporation in the United States and/or other countries.

### Applications

- Spectrometer
- Control and data acquisition of CCD image sensor (S11151-2048)

The table below shows CCD linear image sensors applicable for the C11160. Since the C11160 does not include CCD image sensors, so select the desired sensor and order it separately.

Type no.	Number of pixels	Number of effective pixels	Pixel size (μm)	Image size [mm (H) × mm (V)]
S11151-2048	2056 × 1	2048 × 1	14 × 200	28.672 × 0.200

### Structure

Parameter	Specification	Unit
Output type	Digital	-
A/D conversion resolution	16	bit
Interface	USB 2.0	-

### ▣ Absolute maximum ratings

Parameter	Symbol	Condition	Value	Unit
Supply voltage	Vdd	Ta=25 °C	0 to +6.0	V
Input signal voltage*1	Vi	Ta=25 °C	0 to Vdd	V
Operating temperature*2	Topr		0 to +50	°C
Storage temperature*2	Tstg		-20 to +70	°C

\*1: Trigger input

\*2: No dew condensation

When there is a temperature difference between a product and the surrounding area in high humidity environment, dew condensation may occur on the product surface. Dew condensation on the product may cause deterioration in characteristics and reliability.

Note: Exceeding the absolute maximum ratings even momentarily may cause a drop in product quality. Always be sure to use the product within the absolute maximum ratings.

### ▣ Electrical characteristics (Ta=25 °C)

Parameter	Symbol	Condition	Min.	Typ.	Max.	Unit
Readout frequency*3	fop		-	1	-	MHz
Line rate*4	-		-	-	483	Hz
Conversion gain	Gc	Gain 1	-	3	-	e-/ADU
Trigger output voltage	High level	-	3.8	-	-	V
	Low level		-	-	0.6	
Trigger input voltage	High level	-	-	3.5	5	V
	Low level		-	-	1.5	
Current consumption	Ic	fop=1 MHz	-	360	500	mA
Integration time*5	Tinteg		2071	-	16 777 215	clock

\*3: Fixed

\*4: This is the theoretical value of the line rate that is determined by the internal operation timing of the driver circuit and is different from the line rate defined by the sensor specifications. This value differs from the line rate in a series of processes that acquire data from the circuit to a PC via the USB 2.0 port on the PC.

\*5: 1 clock = 1/1 MHz  $\approx$  1  $\mu$ s

### ▣ Electrical and optical characteristics (Ta=25 °C)

Parameter	Symbol	Condition	Min.	Typ.	Max.	Unit
Readout noise	Nr	Gain 1	-	15	-	ADU
Dynamic range	DR	Gain 1	-	4000	-	-
Operating voltage*6	-		4.75	5	5.25	V

\*6: USB bus powered

**Functions**

Parameter	Specification	
Operation mode display	"Suspend" mode (LED-off)	The power supply is turned off.
	"Standby" mode (LED-white)	It is a standby state, in which the data acquisition is possible.
	"Data transfer" mode (LED-green, aqua, blue)	In this mode, the driver circuit sends the data to PC.
Synchronous mode	Internal synchronous mode ("INT" mode)	Data is acquired on the basis of the trigger timing generated by application software.
	External synchronous mode 1 ("EXT.EDGE" mode)	Data is acquired in synchronization with the external trigger signal input from the BNC connector. In synchronization with an edge of the external trigger signal, data is accumulated for the set integration time and is then output.
Gain adjustment	The gain value can be varied in the range of "1 to 3" with the step of 1.	
Offset adjustment	The offset value can be varied in the range of "-255 to 255" with the step of 1.	
External signal	Input	Acquires data in synchronization with trigger pulse input to the BNC connector
	Output	Sets the timing for the pulse signal output from the pulse output BNC connector of the driver circuit

**Block diagram**

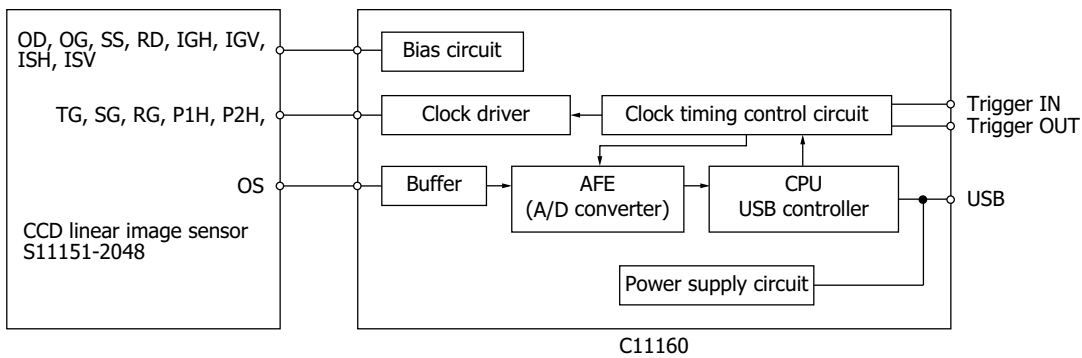

KACCC0756EA

**Timing chart**

Internal synchronous mode ("INT" mode)

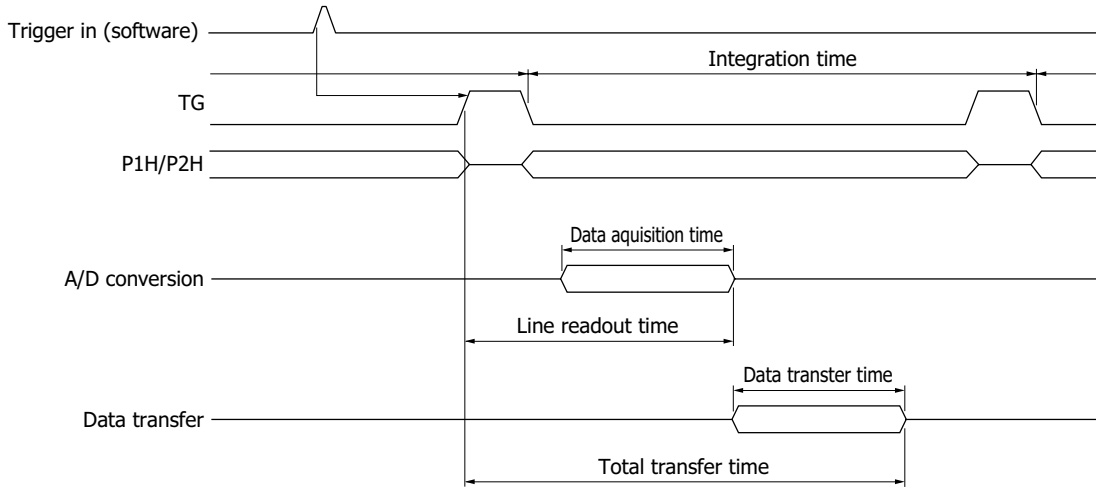

KACCC0670EA

External synchronous mode ("EXT.EDGE" mode)

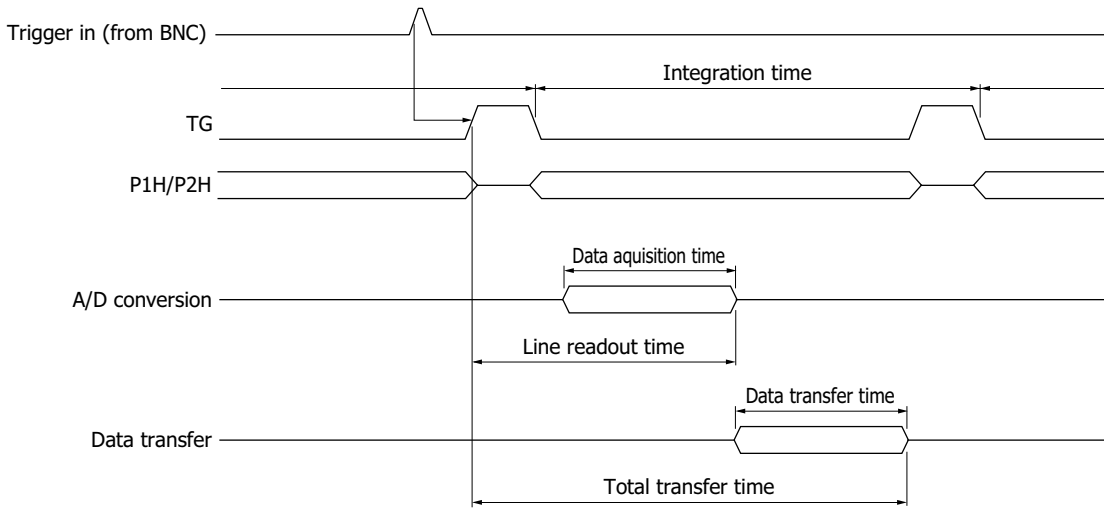

KACCC0671EA

**Dimensional outline (unit: mm)**

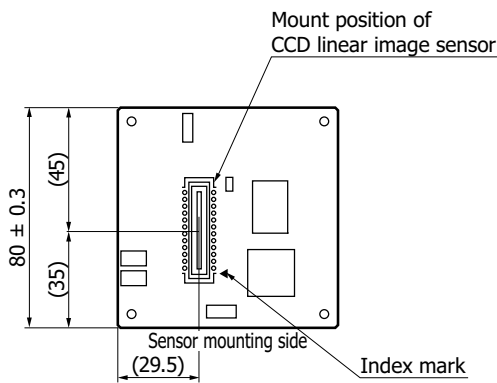
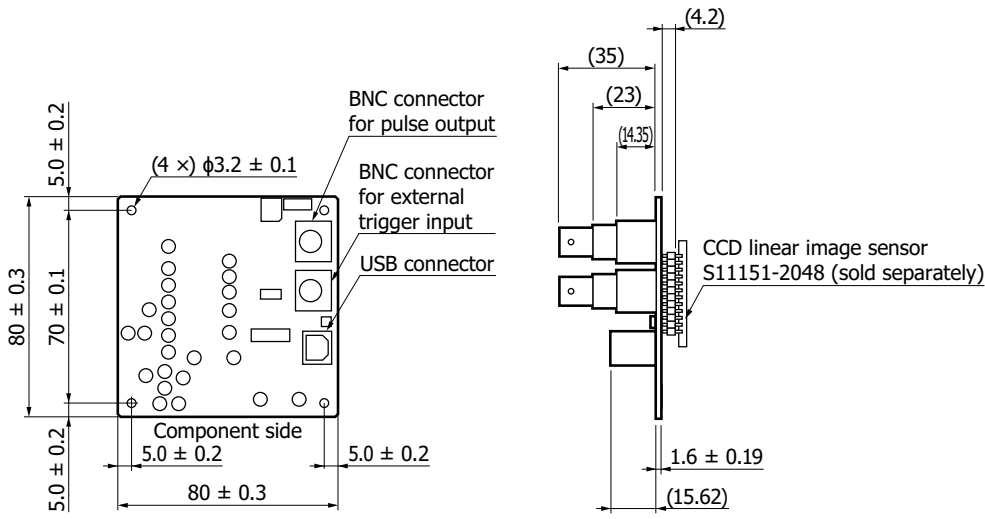

Values in parentheses indicate reference value.  
Weight: approx. 80 g (excluding sensor)

KACCA0318EB

**Connection examples**

Refer to the following diagram to connect hardware peripherals.

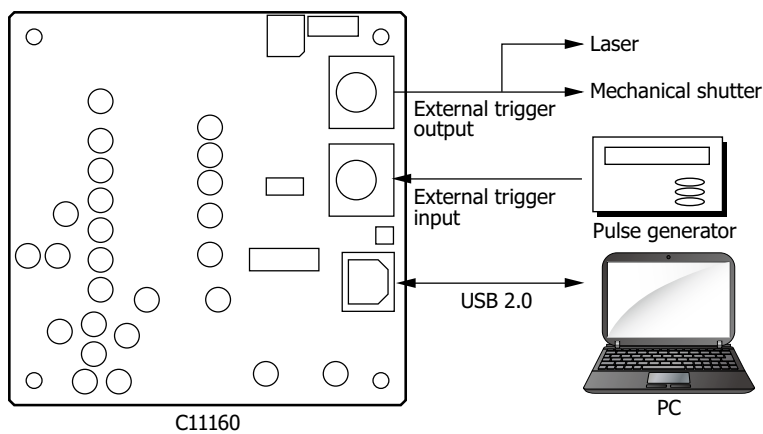

KACCC0669EB

## Accessories

- CD-ROM (includes C11160 instruction manual, application software, SDK)
- USB cable

## Related information

[www.hamamatsu.com/sp/ssd/doc\\_en.html](http://www.hamamatsu.com/sp/ssd/doc_en.html)

### Precautions

- Disclaimer
- Image sensors

Information described in this material is current as of March 2022.

Product specifications are subject to change without prior notice due to improvements or other reasons. This document has been carefully prepared and the information contained is believed to be accurate. In rare cases, however, there may be inaccuracies such as text errors. Before using these products, always contact us for the delivery specification sheet to check the latest specifications.

The product warranty is valid for one year after delivery and is limited to product repair or replacement for defects discovered and reported to us within that one year period. However, even if within the warranty period we accept absolutely no liability for any loss caused by natural disasters or improper product use. Copying or reprinting the contents described in this material in whole or in part is prohibited without our prior permission.

# HAMAMATSU

[www.hamamatsu.com](http://www.hamamatsu.com)

HAMAMATSU PHOTONICS K.K., Solid State Division

1126-1 Ichino-cho, Higashi-ku, Hamamatsu City, 435-8558 Japan, Telephone: (81)53-434-3311, Fax: (81)53-434-5184

U.S.A.: HAMAMATSU CORPORATION: 360 Foothill Road, Bridgewater, NJ 08807, U.S.A., Telephone: (1)908-231-0960, Fax: (1)908-231-1218 E-mail: [usa@hamamatsu.com](mailto:usa@hamamatsu.com)

Germany: HAMAMATSU PHOTONICS DEUTSCHLAND GMBH.: Arzbergerstr. 10, 82211 Herrsching am Ammersee, Germany, Telephone: (49)8152-375-0, Fax: (49)8152-265-8 E-mail: [info@hamamatsu.de](mailto:info@hamamatsu.de)

France: HAMAMATSU PHOTONICS FRANCE S.A.R.L.: 19, Rue du Saule Trapu, Parc du Moulin de Massy, 91882 Massy Cedex, France, Telephone: (33)1 69 53 71 00, Fax: (33)1 69 53 71 10 E-mail: [infos@hamamatsu.fr](mailto:infos@hamamatsu.fr)

United Kingdom: HAMAMATSU PHOTONICS UK LIMITED: 2 Howard Court, 10 Tewin Road, Welwyn Garden City, Hertfordshire AL7 1BW, UK, Telephone: (44)1707-294888, Fax: (44)1707-325777 E-mail: [info@hamamatsu.co.uk](mailto:info@hamamatsu.co.uk)

North Europe: HAMAMATSU PHOTONICS NORDEN AB: Torshamnsgatan 35 16440 Kista, Sweden, Telephone: (46)8-509 031 00, Fax: (46)8-509 031 01 E-mail: [info@hamamatsu.se](mailto:info@hamamatsu.se)

Italy: HAMAMATSU PHOTONICS ITALIA S.R.L.: Strada della Moia, 1 int. 6, 20044 Arese (Milano), Italy, Telephone: (39)02-93 58 17 33, Fax: (39)02-93 58 17 41 E-mail: [info@hamamatsu.it](mailto:info@hamamatsu.it)

China: HAMAMATSU PHOTONICS (CHINA) CO., LTD.: 1201 Tower B, Jiaming Center, 27 Dongsanhuan Beilu, Chaoyang District, 100020 Beijing, P.R. China, Telephone: (86)10-6586-6006, Fax: (86)10-6586-2866 E-mail: [hpc@hamamatsu.com.cn](mailto:hpc@hamamatsu.com.cn)

Taiwan: HAMAMATSU PHOTONICS TAIWAN CO., LTD.: 8F-3, No.158, Section 2, Gongdao 5th Road, East District, Hsinchu, 300, Taiwan R.O.C. Telephone: (886)3-659-0080, Fax: (886)3-659-0081 E-mail: [info@hamamatsu.com.tw](mailto:info@hamamatsu.com.tw)