

# Near infrared/proximity type sensor

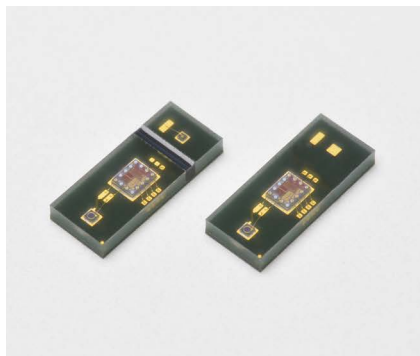

P13567-02CT G13568-02CT

## I<sup>2</sup>C interface-compatible near IR sensor

These are compact optical devices that integrate an InGaAs photodiode and IC. Signal from a photodiode that receives near infrared light is output digitally through an I<sup>2</sup>C interface. A type with a built-in LED (P13567-02CT) and a type that includes a built-in LED driver and supports external LEDs (G13568-02CT) are available.

### Features

- I<sup>2</sup>C interface
- Low supply voltage: Vdd=2.25 V to 3.63 V
- I<sup>2</sup>C bus voltage: 1.65 V
- Low current consumption
- Small package (7.7 × 3.1 × 1.0 mm)
- Supports lead-free reflow soldering
- Built-in 16-bit A/D converter
- Built-in LED type (P13567-02CT)  
External LED type (G13568-02CT)

### Applications

- Moisture level detection
- NIR (near infrared) photometry

### Structure

Parameter	P13567-02CT	<b>NEW</b> G13568-02CT	Unit
Detector	InGaAs PIN photodiode		-
Photosensitive area	φ0.3		mm
Emitter	Infrared LED	-	-
Emitter area	0.31 × 0.31	-	mm
Package	Plastic		-

### Absolute maximum ratings (Ta=25 °C)

Parameter	Symbol	Condition	P13567-02CT	<b>NEW</b> G13568-02CT	Unit
Supply voltage	Vdd		-0.3 to +4		V
Load current	Io		±10		mA
Power dissipation	P		100		mW
Operating temperature	Topr	No dew condensation*1	-30 to +80		°C
Storage temperature	Tstg	No dew condensation*1	-40 to +85		°C
LED drive current	DC mode	IF	80	64 (total value of 3 terminals)	mA
	Pulse mode	IFP	80	50	
Reverse voltage*2	VR		1	5	V
Soldering temperature*3	Tsol		260 (3 times)		°C

\*1: When there is a temperature difference between a product and the surrounding area in high humidity environment, dew condensation may occur on the product surface. Dew condensation on the product may cause deterioration in characteristics and reliability.

\*2: When driven externally

\*3: Reflow soldering, IPC/JEDEC J-STD-020 MSL3, see P.19

Note: Exceeding the absolute maximum ratings even momentarily may cause a drop in product quality. Always be sure to use the product within the absolute maximum ratings.

### Recommended operating conditions

Parameter	Symbol	Condition	Min.	Typ.	Max.	Unit
Supply voltage	Vdd		2.25	3.3	3.63	V
I <sup>2</sup> C bus pull-up voltage*4	Vbus	Rp=2.2 kΩ	1.65	3.3	Vdd + 0.5	V
High level input voltage	Vih	SDA, SCL	1.55	-	Vdd + 0.5	V
Low level input voltage	Vil	SDA, SCL	-0.5	-	0.3 × Vbus	V
Bus capacitance	Cbus	SDA, SCL	-	-	400	pF
Maximum incident light level	-	Light source A	-	-	100	lx

\*4: The pull-up resistance is determined by the Cbus capacitance and Vbus voltage. Satisfy the following condition: Vdd - Vbus < 1.2 V.

### Electrical and optical characteristics

#### P13567-02CT

■ Sensor section (Ta=25 °C, Vdd=Vbus=Vnode=3.3 V, LED: λp=1.45 μm, initial setting: high gain, integration time: 100 ms, unless otherwise noted)

Parameter	Symbol	Condition	Min.	Typ.	Max.	Unit	
Spectral response range	λ		-	0.9 to 1.7	-	μm	
Peak sensitivity wavelength	λp		-	1.55	-	μm	
Current consumption	Operation mode	Iddc	E=0 lx (dark state), excluding output current	30	75	150	μA
	Standby mode	Idds		0.1	1.0	3.0	
Dark count (when LED is in standby)	Sd	Dark state, initial setting	-	-	10	counts	
Dark count (when LED is being driven)	Sdl	Dark state *5	0	3000	7500	counts	
Sensitivity	High gain	Sh	Object: aluminum, distance to object: 1 mm *6	22500	50000	80000	counts/mW
Sensitivity gain ratio	High/Low	-	4.8	-	7.9	times	

\*5: LED driver (DC mode, If=8 mA), integration time=100 ms

\*6: LED driver (DC mode, If=0.8 mA), integration time=100 ms

■ I<sup>2</sup>C section (Ta=25 °C, Vdd=Vbus=3.3 V, unless otherwise noted)

Parameter	Symbol	Condition	Min.	Typ.	Max.	Unit
I <sup>2</sup> C address	ADDR	7-bit	0 × 2A			
I <sup>2</sup> C clock frequency	fclk		1	-	400	kHz
SDA output voltage	High level	Voh	Rp=2.2 kΩ	0.8Vbus	-	V
	Low level	Vol	Rp=2.2 kΩ	0	0.4	V
I/O terminal capacitance	Ci		-	-	20	pF
SDA output fall time*7	tf	Rp=2.2 kΩ, Cp=400 pF	-	-	250	ns

\*7: The SDA output rise time is determined by the time constant defined by Cbus × Rp.

Note: I<sup>2</sup>C interface (SDA, SCL) timing complies with "The I<sup>2</sup>C-bus specification version 2.1".

■ LED section (Ta=25 °C, Vnode=Vdd=3.3 V, unless otherwise noted)

Parameter	Symbol	Condition	Min.	Typ.	Max.	Unit
Peak emission wavelength	λp	If=50 mA	1.4	1.45	1.5	μm
Spectral half width	Δλ	If=50 mA	-	120	170	nm
Radiant flux	φe	If=50 mA	1.8	2.4	-	mW
Forward voltage	Vf	If=50 mA	-	1.0	1.5	V
Reverse current	Ir	Vr=1 V	-	-	10	μA
Cutoff frequency*8	fc	If=50 mA ± 10 mAp-p	-	15	-	MHz
Rise time	tr	20% to 80%*9	-	22	-	μs
Fall time	tf	80% to 20%*9	-	27	-	μs

\*8: Frequency at which the light output drops by 3 dB relative to the output at 100 kHz

\*9: When If=8 mA in LED pulse mode

## G13568-02CT

## ■ Sensor area (Ta=25 °C, Vdd=Vbus=3.3 V, unless otherwise noted)

Parameter	Symbol	Condition	Min.	Typ.	Max.	Unit	
Spectral response range	$\lambda$		-	0.9 to 1.7	-	$\mu\text{m}$	
Peak sensitivity wavelength	$\lambda_p$		-	1.55	-	$\mu\text{m}$	
Current consumption	Operation mode	Iddc	E=0 lx (dark state), excluding output current	25	75	150	$\mu\text{A}$
	Standby mode	Idds		0.1	1.0	3.0	
Dark count	Sd	E=0 lx (dark state), initial setting	-	-	10	counts	
Sensitivity	High gain	Sh	Light source A 100 lx	500	-	2500	counts/lx
Sensitivity gain ratio	High gain	-		4.8	-	7.9	times

■ I<sup>2</sup>C area (Ta=25 °C, Vdd=Vbus=3.3 V, unless otherwise noted)

Parameter	Symbol	Condition	Min.	Typ.	Max.	Unit
I <sup>2</sup> C address	ADDR	7-bit	0 × 2A			
I <sup>2</sup> C clock frequency	fclk		1	-	400	kHz
SDA, SCL output voltage	High level	Voh	Rp=2.2 k $\Omega$	0.8Vbus	-	V
	Low level	Vol	Rp=2.2 k $\Omega$	0	-	0.4
I/O terminal capacitance	Ci		-	-	20	pF
SDA/SCL output fall time*10	tf	Rp=2.2 k $\Omega$ , Cp=400 pF	-	-	250	ns

\*10: The SCL/SDA output rise time is determined by the time constant defined by Cbus × Rp.

Note: I<sup>2</sup>C interface (SDA, SCL) timing complies with "The I<sup>2</sup>C-bus specification version 2.1".

## ■ Register map

Adrs	Function	bit							
		7	6	5	4	3	2	1	0
00	RGB sensor control	Reset	Standby function	Standby function monitor	Register reset	Gain selection	Integration mode	Integration time setting	
01	Manual timing (high byte)	Manual timing (low byte)							
02	Manual timing (low byte)								
03	Output data (high byte)	Anode channel data (16 bits)							
04	Output data (low byte)								
05	-	Not used							
06	-								
07	-								
08	-								
09	-								
0A	-								
0B	-								
0C	-								
0D	-								
0E	LED drive control 1								
0F	LED drive control 2	LED1 drive current selection				*12			

\*11: LED2 drive current selection (G13568-02CT)

\*12: LED3 drive current selection (G13568-02CT)

Note: We recommend that the LEDs be used in DC mode.

## ■ Details of 00, 0E, 0F

P13567-02CT									
Adrs	bit								
	7	6	5	4	3	2	1	0	
00	Initial setting	Reset	Standby	Standby function monitor	Register reset	Gain	Integration mode	Integration time	
		1	1	-	1	0	1	0	0
	Function	0: Operation 1: reset	0: Operation 1: Standby	Readout only	0: Reset release 1: Address 03-0A Data reset	0: High gain 1: Low gain	0: Fixed time mode 1: Manual setting mode	(00) 32 $\mu$ s (01) 0.5 ms (10) 8.2 ms (11) 65.5 ms	
0E	Initial setting	LED reset	LED standby	DC mode	1/10 mode				
		1	1	0	0				
	Function	0: Operation 1: reset	0: Operation 1: Standby	0: Pulse mode 1: DC mode	0: Normal mode 1: 1/10 mode				
0F	Initial setting	LED drive current							
		0	0	0	0				
	Function	0: 0 mA 1: 64 mA	0: 0 mA 1: 32 mA	0: 0 mA 1: 16 mA	0: 0 mA 1: 8 mA				

G13568-02CT									
Adrs	bit								
	7	6	5	4	3	2	1	0	
0	Initial setting	Reset	Standby	Standby function monitor	Register reset	Gain	Integration mode	Integration time	
		1	1	-	1	0	1	0	0
	Function	0: Operation 1: reset	0: Operation 1: Standby	Readout only	0: Reset release 1: Address 03-0A Data reset	0: High gain 1: Low gain	0: Fixed time mode 1: Manual setting mode	(00) 32 $\mu$ s (01) 0.5 ms (10) 8.2 ms (11) 65.5 ms	
0E	Initial setting	LED reset	LED standby	DC mode	1/10 mode	LED2 drive current (0 mA) <sup>*13</sup>			
		1	1	0	0	0	0	0	0
	Function	0: Operation 1: reset	0: Operation 1: Standby	0: Pulse mode 1: DC mode	0: Normal mode 1: 1/10 mode	0: 0 mA 1: 64 mA	0: 0 mA 1: 32 mA	0: 0 mA 1: 16 mA	0: 0 mA 1: 8 mA
0F	Initial setting	LED1 drive current (0 mA) <sup>*13</sup>				LED3 drive current (0 mA) <sup>*13</sup>			
		0	0	0	0	0	0	0	0
	Function	0: 0 mA 1: 64 mA	0: 0 mA 1: 32 mA	0: 0 mA 1: 16 mA	0: 0 mA 1: 8 mA	0: 0 mA 1: 64 mA	0: 0 mA 1: 32 mA	0: 0 mA 1: 16 mA	0: 0 mA 1: 8 mA

\*13: Set to the total of the currents selected with the four bit parameters.

## Program example

Condition 1: Initial settings [manual setting mode,  $T_{int}=00$  (32  $\mu$ s), integration time=100 ms/ch (manual timing register set to 0x0C30)]

### command

Action		Data body								Ack	Remark
Address call (0x2A)	S	0	1	0	1	0	1	0	W	A	7-bit address
Register call (0x00)		0	0	0	0	0	0	0	0	A	Specifies the control byte
Register write (0x84)		1	0	0	0	0	1	0	0	A	ADC reset, standby release
Address call (0x2A)	Sr	0	1	0	1	0	1	0	W	A	Restart, address
Register call (0x00)		0	0	0	0	0	0	0	0	A	Specifies the control byte
Register write (0x04)		0	0	0	0	0	1	0	0	A	P ADC reset release, bus release
Stands by for longer than the integration time (standby time > 400 ms)											
Address call (0x2A)	S	0	1	0	1	0	1	0	W	A	7-bit address
Register call (0x03)		0	0	0	0	0	1	0	1	A	Specifies the sensor data byte
Address call (0x2A)	Sr	0	1	0	1	0	1	0	R	A	Changes to read mode
Data read out (MSB)		X	X	X	X	X	X	X	X	A	Data output
Data read out (LSB)		X	X	X	X	X	X	X	X	$\bar{A}$	P

S=Start condition, Sr=Restart condition, A=Acknowledge,  $\bar{A}$ =Acknowledge by host, P=Stop condition, R=Read mode (1), W=Write mode (0),  $\bar{A}$ =not acknowledge

### Format

The rest is the same as the above command list.

S	0x2A (7 bits)	W	A	0x00	A	0x84	A
---	---------------	---	---	------	---	------	---

Sr	0x2A (7 bits)	W	A	0x00	A	0x04	A	P
----	---------------	---	---	------	---	------	---	---

When the SCL clock is 400 kHz, the write time is 135  $\mu$ s.

Standby

S	0x2A (7 bits)	W	A	0x03	A	Sr	0x2A (7 bits)	R	A
---	---------------	---	---	------	---	----	---------------	---	---

Sensor data	A	Sensor data	$\bar{A}$	P
-------------	---	-------------	-----------	---

The readout time is 112.5  $\mu$ s.

from master to slave       from slave to master

Condition 2: [Fixed time mode, Tint=01 (0.5 ms), integration time=1.0 ms/ch]

## ■ Command

Action		Data body								Ack	Remark
Address call (0x2A)	S	0	1	0	1	0	1	0	W	A	7-bit address
Register call (0x00)		0	0	0	0	0	0	0	0	A	Specifies the control byte
Register write (0x81)		1	0	0	0	0	0	0	1	A	ADC reset, standby release
Address call (0x2A)	Sr	0	1	0	1	0	1	0	W	A	Restart, bit address
Register call (0x00)		0	0	0	0	0	0	0	0	A	Specifies the control byte
Register write (0x01)		0	0	0	0	0	0	0	1	A	P ADC reset release, bus release
Stands by for longer than the integration time. Measurement takes place during standby (standby time > 4 ms). Measurements are repeated continuously.											
Address call (0x2A)	S	0	1	0	1	0	1	0	W	A	7-bit address
Register call (0x03)		0	0	0	0	0	1	0	1	A	Specifies the sensor data byte
Address call (0x2A)	Sr	0	1	0	1	0	1	0	R	A	Changes to read mode
Data read out (infrared: MSB)		X	X	X	X	X	X	X	X	A	Data output
Data read out (infrared: LSB)		X	X	X	X	X	X	X	X	$\bar{A}$	P

S=Start condition, Sr=Restart condition, A=Acknowledge,  $\bar{A}$ =Acknowledge by host, P=Stop condition, R=Read mode (1), W=Write mode (0),  $\bar{A}$ =not acknowledge

## ■ Format

The rest is the same as the above command list.

S	0x2A (7 bits)	W	A	0x00	A	0x81	A
---	---------------	---	---	------	---	------	---

Sr	0x2A (7 bits)	W	A	0x00	A	0x01	A	P
----	---------------	---	---	------	---	------	---	---

When the SCL clock is 400 kHz, the write time is 135  $\mu$ s.

Standby

S	0x2A (7 bits)	W	A	0x03	A	Sr	0x2A (7 bits)	R	A
---	---------------	---	---	------	---	----	---------------	---	---

Sensor data	A	Sensor data	$\bar{A}$	P
-------------	---	-------------	-----------	---

The readout time is 112.5  $\mu$ s.

from master to slave       from slave to master

Condition 3: [Manual setting mode, Tint=01 (0.5 ms), manual timing=357 (0x165), integration time=357 ms/ch, low gain]

#### ■ Command

Action		Data body								Ack	Remark	
Address call (0x2A)	S	0	1	0	1	0	1	0	0	W	A	7-bit address
Register call (0x00)		0	0	0	0	0	0	0	0	0	A	Specifies the control byte
Register write (0x8D)		1	0	0	0	1	1	0	1	1	A	ADC reset, standby release
Register write (0x01)		0	0	0	0	0	0	0	1	1	A	Manual timing high byte
Register write (0x65)		0	1	1	0	0	1	0	1	1	A	Manual timing low byte
Address call (0x2A)	Sr	0	1	0	1	0	1	0	0	W	A	Restart, 7-bit address
Register call (0x00)		0	0	0	0	0	0	0	0	0	A	Specifies the control byte
Register write (0x0D)		0	0	0	0	1	1	0	1	1	A	P   ADC reset release, bus release
Stands by for longer than the integration time. Measurement takes place during standby (standby time > 1428 ms). Measurements are repeated continuously.												
Address call (0x2A)	S	0	1	0	1	0	1	0	0	W	A	7-bit address
Register call (0x03)		0	0	0	0	0	1	0	1	1	A	Specifies the sensor data byte
Address call (0x2A)	Sr	0	1	0	1	0	1	0	0	R	A	Changes to read mode
Data read out (MSB)		X	X	X	X	X	X	X	X	X	A	Data output
Data read out (LSB)		X	X	X	X	X	X	X	X	X	$\bar{A}$   P	

S=Start condition, Sr=Restart condition, A=Acknowledge,  $\bar{A}$ =Acknowledge by host, P=Stop condition, R=Read mode (1), W=Write mode (0),  $\bar{A}$ =not acknowledge

#### ■ Format

The rest is the same as the above command list.

S	0x2A (7 bits)	W	A	0x00	A	0x85	A
---	---------------	---	---	------	---	------	---

0x01	A	0x65	A
------	---	------	---

Sr	0x2A (7 bits)	W	A	0x00	A	0x0D	A	P
----	---------------	---	---	------	---	------	---	---

When the SCL clock is 400 kHz, the write time is 180  $\mu$ s.

Standby

S	0x2A (7 bits)	W	A	0x03	A	Sr	0x2A (7 bits)	R	A
---	---------------	---	---	------	---	----	---------------	---	---

Sensor data	A	Sensor data	$\bar{A}$	P
-------------	---	-------------	-----------	---

The readout time is 112.5  $\mu$ s.

from master to slave       from slave to master

Condition 4: (LED drive DC mode, LED drive current=48 mA)

## ■ Command

· When starting operation

Action		Data body								Ack	Remark
Address call (0x2A)	S	0	1	0	1	0	1	0	W	A	7-bit address
Register call (0x0E)		0	0	0	0	1	1	1	0	A	Specifies the control byte
Register write (0xA0)		1	0	1	0	0	0	0	0	A	Standby release, DC mode
Register write (0x60)		0	1	1	0	0	0	0	0	A	Drive current
Address call (0x2A)	Sr	0	1	0	1	0	1	0	W	A	Restart, 7-bit address
Register call (0x0E)		0	0	0	0	1	1	1	0	A	Specifies the control byte
Register write (0x20)		0	0	1	0	0	0	0	0	A	P LED driver reset release, bus release

· When ending operation

Action		Data body								Ack	Remark
Address call (0x2A)	S	0	1	0	1	0	1	0	W	A	7-bit address
Register call (0x0E)		0	0	0	0	1	1	1	0	A	Specifies the control byte
Register write (0xC0)		1	1	0	0	0	0	0	0	A	P Standby

S=Start condition, Sr=Restart condition, A=Acknowledge, A=Acknowledge by host, P=Stop condition, R=Read mode (1), W=Write mode (0),  $\bar{A}$ =not acknowledge

## ■ Format

The rest is the same as the above command list.

· When starting operation

S	0x2A (7 bits)	W	A	0x0E	A	0xA1	A
---	---------------	---	---	------	---	------	---

0x60	A
------	---

Sr	0x2A (7 bits)	W	A	0x0E	A	0x20	A	P
----	---------------	---	---	------	---	------	---	---

· When ending operation

S	0x2A (7 bits)	W	A	0x0E	A	0xC0	A	P
---	---------------	---	---	------	---	------	---	---

from master to slave       from slave to master



## Flowcharts

### ■ Sensor section

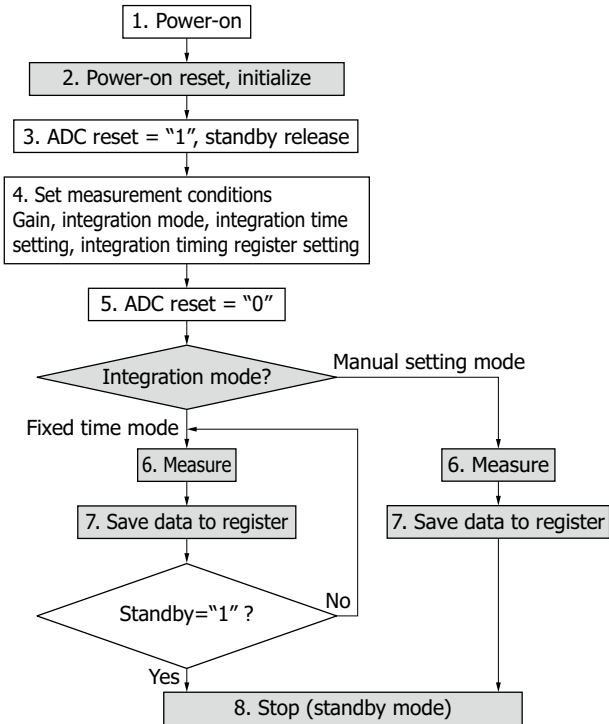

After power-on, the built-in power-on reset circuit operates to set all registers to their initial conditions (2.).

With the initial settings, the product is in standby mode, waiting for commands.

To set measurement conditions, enter commands via the I<sup>2</sup>C bus. This product starts measuring when ADC reset changes from 1 to 0. Therefore, to write to registers, ADC reset must be set to 1 (3.). After setting measurement conditions (4.), release ADC reset to start measuring (5.). There are two operation modes: fixed time mode and manual setting mode. In manual setting mode, the product automatically enters standby mode after completing a single measurement. In fixed time mode, the product repeats measurement and data storage. During this repetition, if ADC reset or standby is set to 1 with an I<sup>2</sup>C command, the product stops its operation.

### ■ LED driver

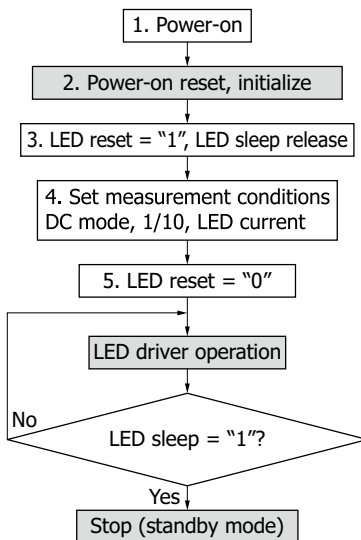

With the initial settings, the LED drivers are also in standby mode. Therefore, first disable the standby mode (3.). Next, set the LED current, 1/10 mode, DC mode, and the like. Then, release the reset to start operating (4. 5.). LED drivers continue to operate until they are set to standby mode. To end operation, enable standby mode.

**Spectral response**

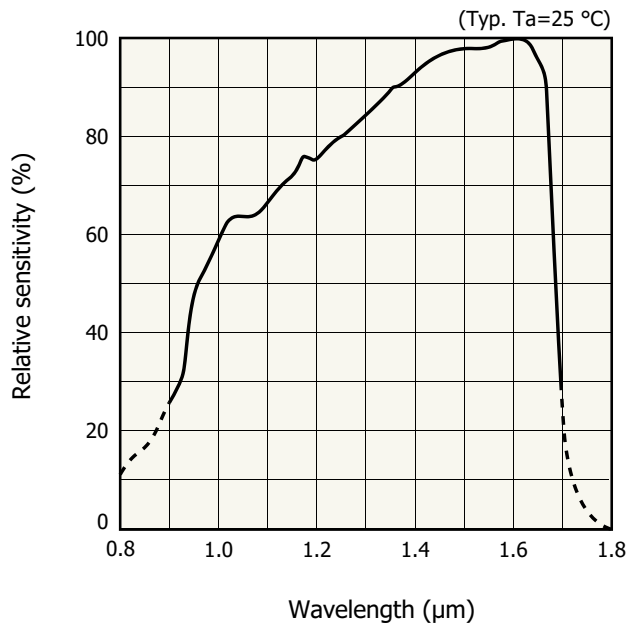

**Directivity**

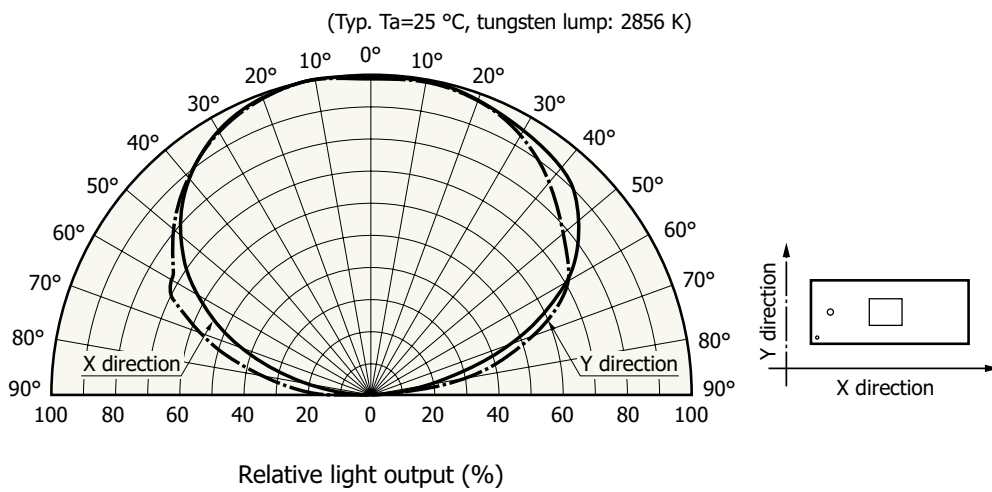

**Emission spectrum (P13567-02CT)**

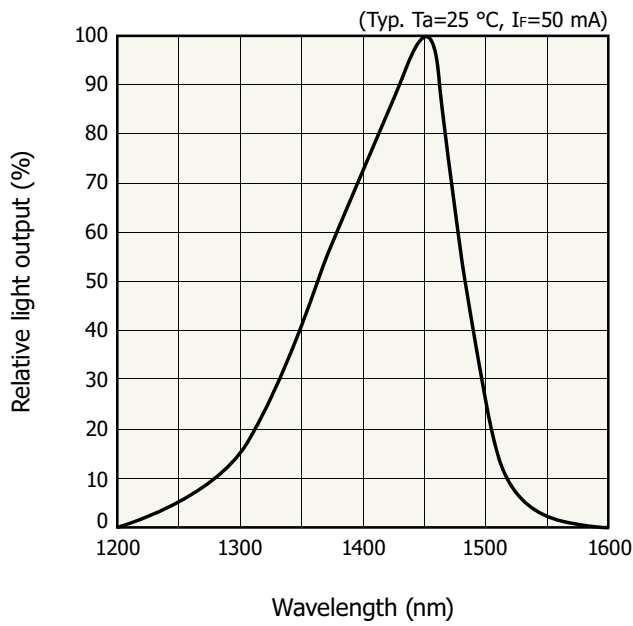

KPICB0221EA

**Light output vs. ambient temperature (P13567-02CT)**

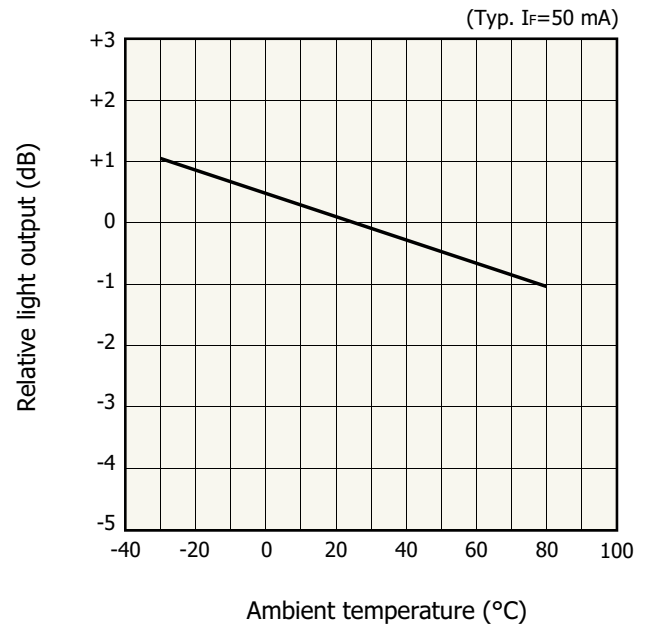

KPICB0223EB

**Allowable forward current vs. ambient temperature (P13567-02CT)**

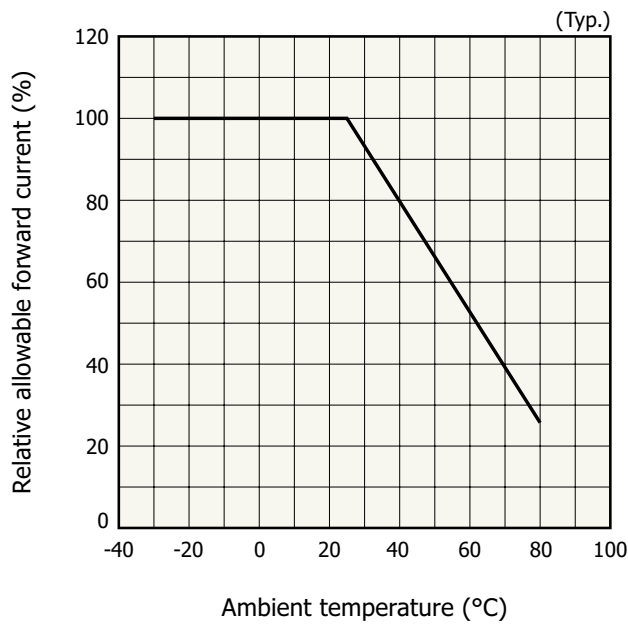

KPICB0224EB

**Current consumption vs. ambient temperature**

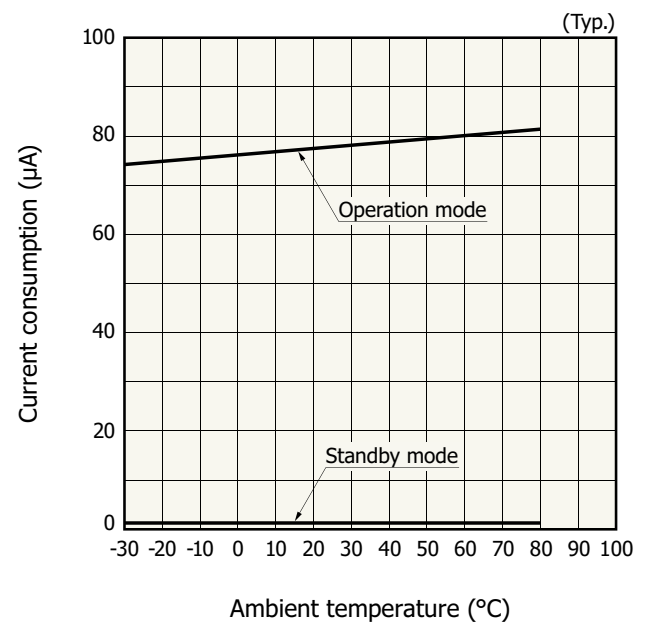

KPICB0367EA

**Sensitivity vs. ambient temperature**

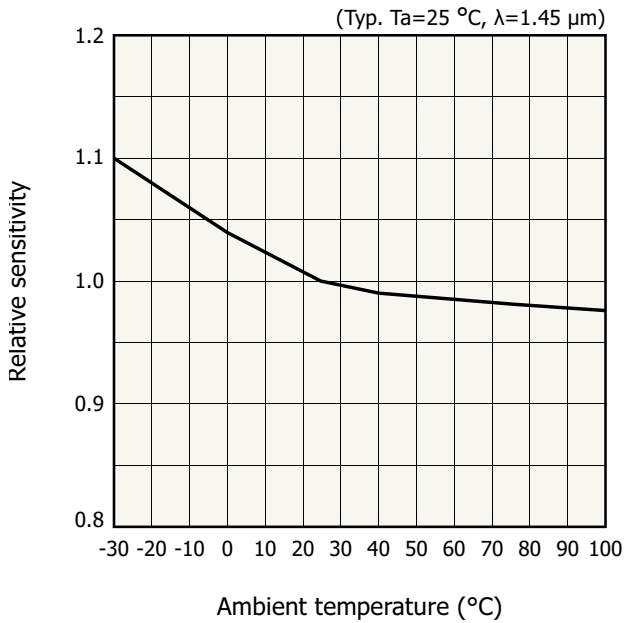

KPIC80207EB

**Measurement example of moisture level**

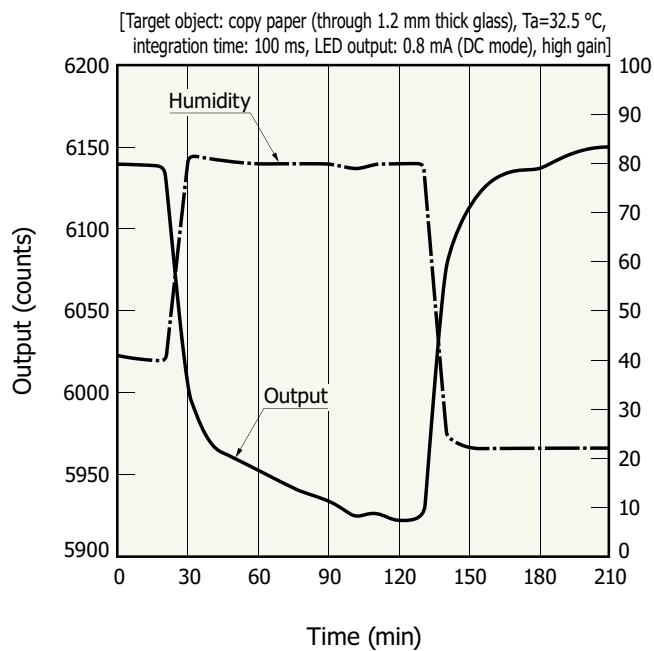

KPIC80236EA

The moisture level of the copy paper is detected when the humidity is changed (40% to 80% to 20%).

**Output vs. distance between sensor and target object**

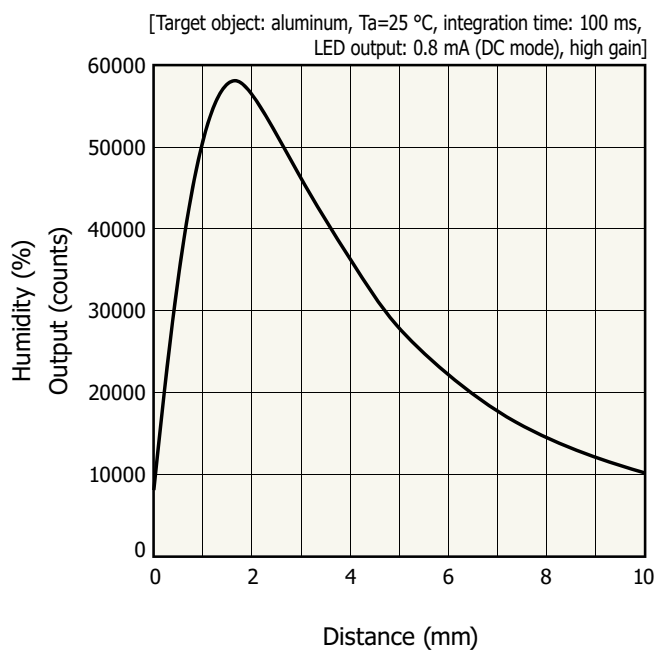

KPIC80344EA

The sensor output is maximum when the distance between the sensor and target object is about 1.5 mm.

**Cross section (unit: mm)**

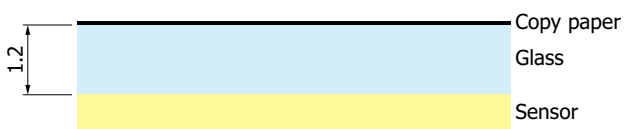

KPIC00313EA

**Block diagram**

P13567-02CT

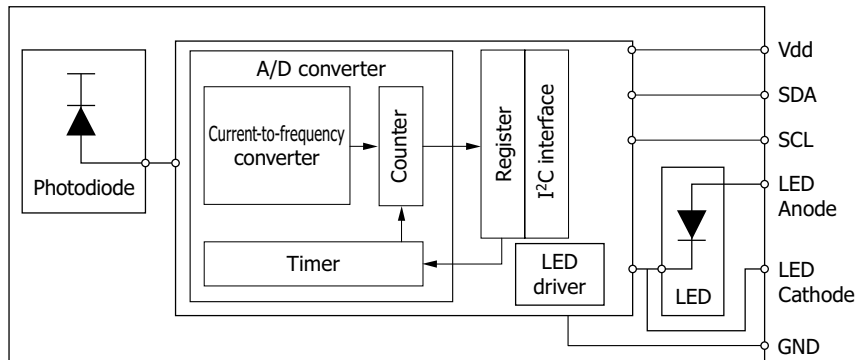

KPIC0299EB

G13568-02CT

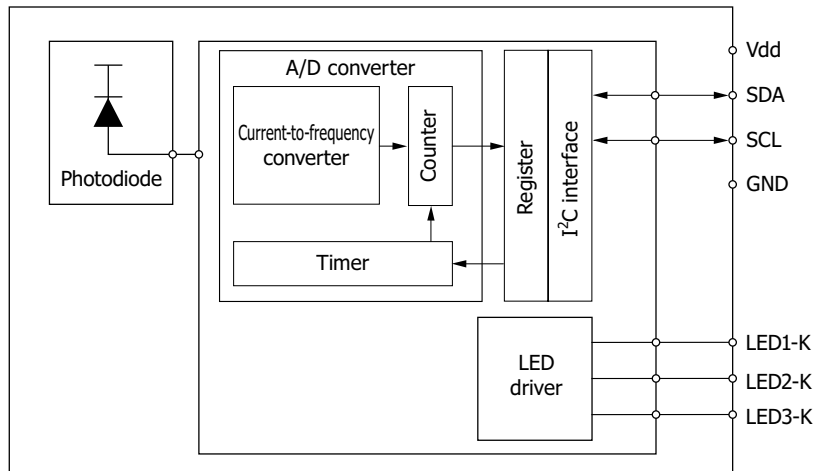

KPIC0292EB

### Connection example

P13567-02CT

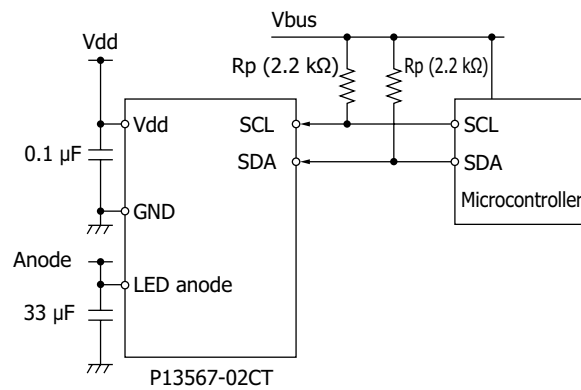

Note: When the LED is emitting light, do not externally control the LED.  
 If you are using Vdd and Vbus at different voltages, use them in the range that satisfies  $V_{dd} - V_{bus} < 1.2$  V.  
 Set the LED's anode voltage to  $V_f + 0.5$  V or higher of the LED in use.  
 Leave the LED cathode open.

KPICC0374EC

G13568-02CT

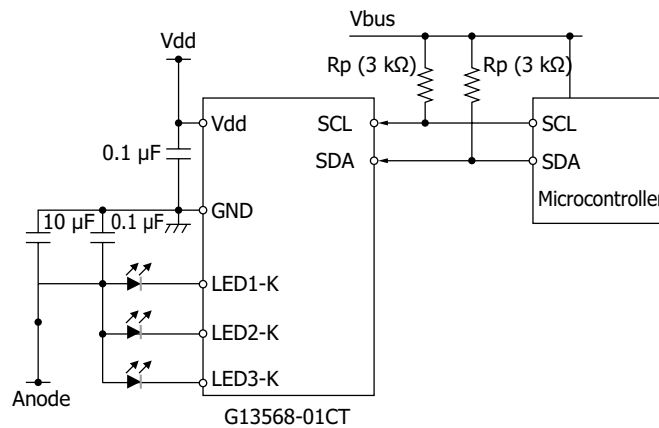

KPICC0296EB

## Timing chart

### ■ Sensor section (manual mode)

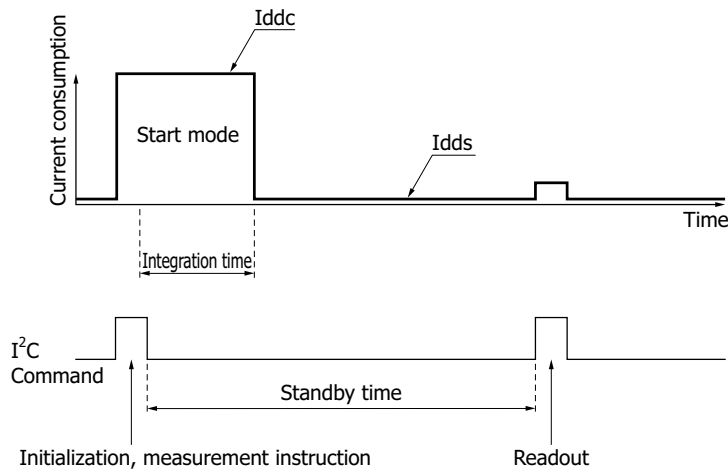

The photodiode data is stored temporarily in a buffer register (not the I<sup>2</sup>C register). After the completion of the measurement, the entire set of data is stored in the I<sup>2</sup>C register. If this product is set to manual mode, after the integration time elapses, it will automatically switch to sleep mode. I<sup>2</sup>C register values are not initialized with ADC reset or in standby mode. They are initialized only during a power-on reset when the power is turned on. The integration time per cycle is the sum of the three detection times indicated in the timing chart on the left.

- Initialization, measurement instruction
- Standby time (> integration time)
- Readout time

KPICC0293EA

### ■ Sensor section (fixed time mode)

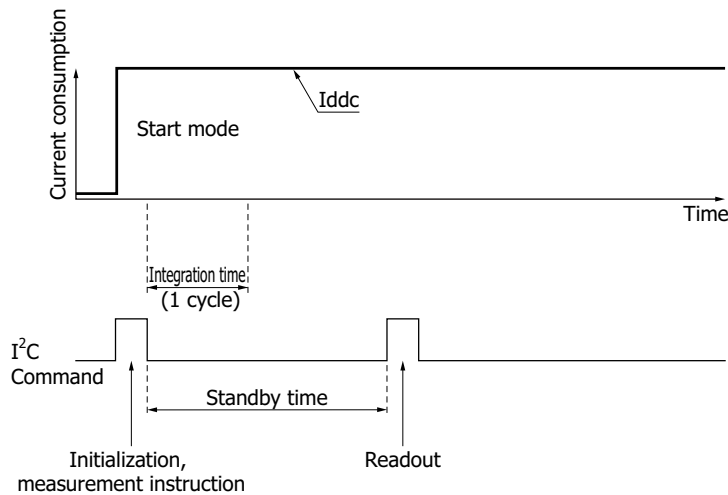

The measurement time is the shortest under the following conditions.

<Conditions>

- Fixed time mode,  $T_{int}=00$  (32  $\mu$ s)
- Integration time: 32  $\mu$ s/ch
- SCL frequency: 400 kHz
- Initialization, measurement instruction: 135  $\mu$ s
- Standby time (> integration time): 128  $\mu$ s
- Readout time: 112.5  $\mu$ s

Measurement time: 375.5  $\mu$ s

KPICC0294EA

## ■ LED driver (pulse drive)

## P13567-02CT

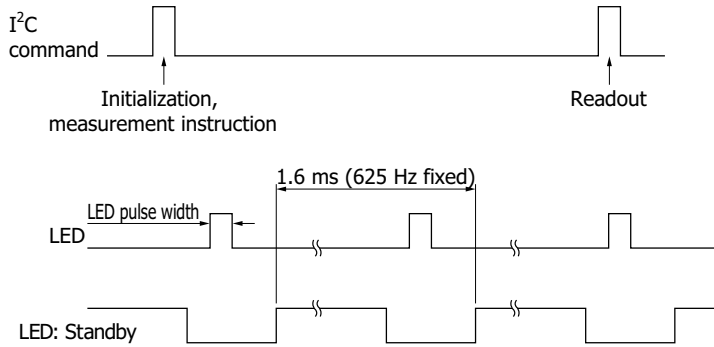

KPICCO300EA

The LED driver can set the light emission pulse width in the range of 0  $\mu$ s to 240  $\mu$ s in 16  $\mu$ s steps (16 levels total). The light emission cycle is approximately 1.6 ms. The drive current is fixed at 8 mA.

When set to low current mode, the drive current is reduced to one-tenth (0.8 mA).

We recommend that you use the LED driver in DC mode.

## G13568-02CT

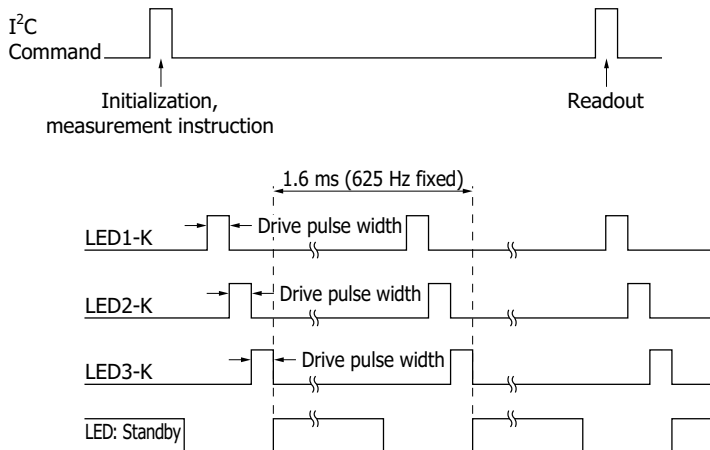

KPICCO295EA

The 3-channel drivers operate in the order LED1-K, LED2-K, and LED3-K. The drive pulse width can be set in the range of 0  $\mu$ s to 240  $\mu$ s in 16- $\mu$ s steps (16 levels total). Drive pulse can be set separately for each LED. The drive cycle is fixed at approximately 1.6 ms, and the drive current is fixed at 8 mA.

If set to low current mode, the current is set to 0.8 mA, which is 1/10 the initial setting.



**Dimensional outline (unit: mm)**

P13567-02CT

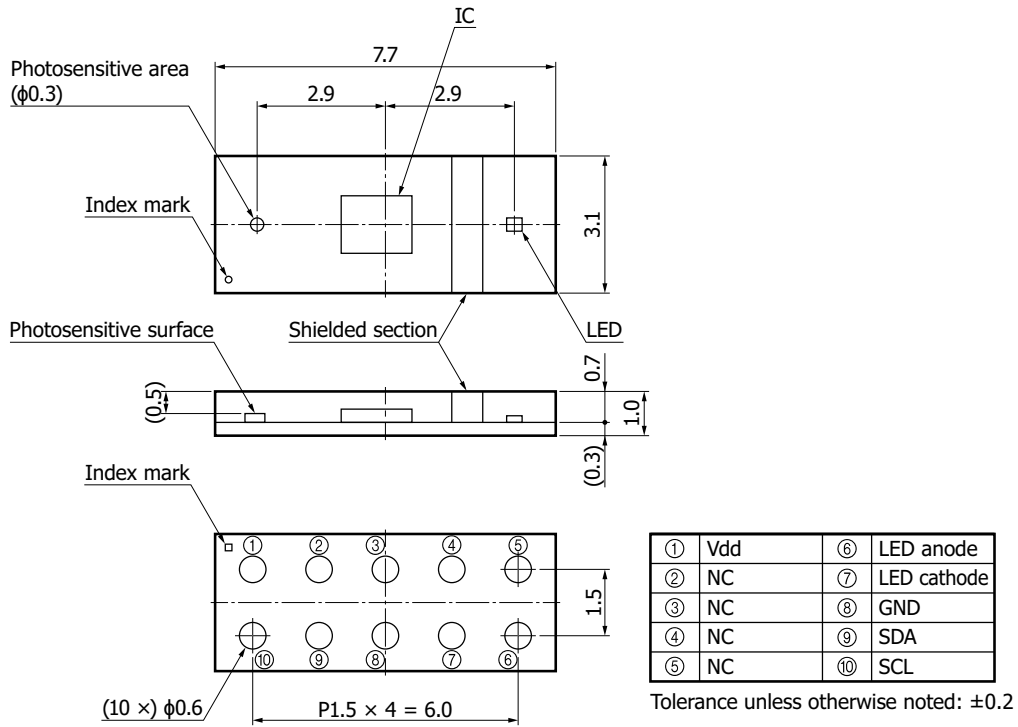

KPICA0115EA

G13568-02CT

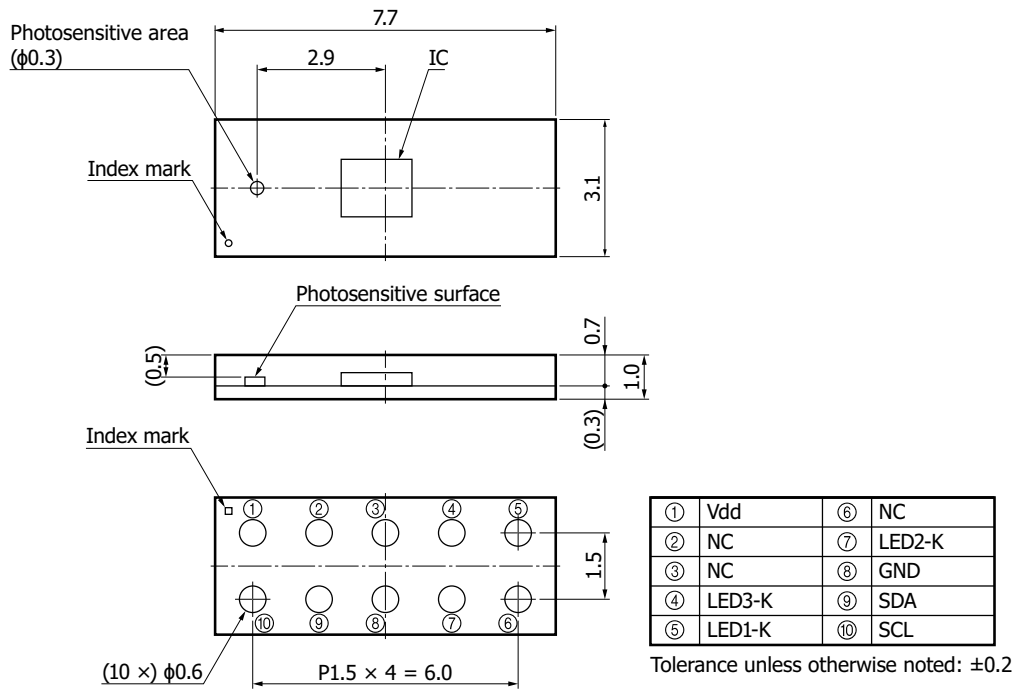

KPICA0119EA

Note: When using this product, contact us for technical information. Please check the technical information first, and then create an appropriate device design.

Recommended land pattern (unit: mm)

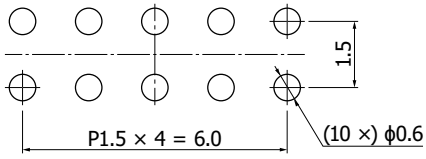

KPIC0372EB

Standard packing specifications

Reel

Dimensions	Hub diameter	Tape width	Material	Electrostatic characteristics
180 mm	60 mm	16 mm	PS	Conductive

Embossed tape (unit: mm, material: PS, conductive)

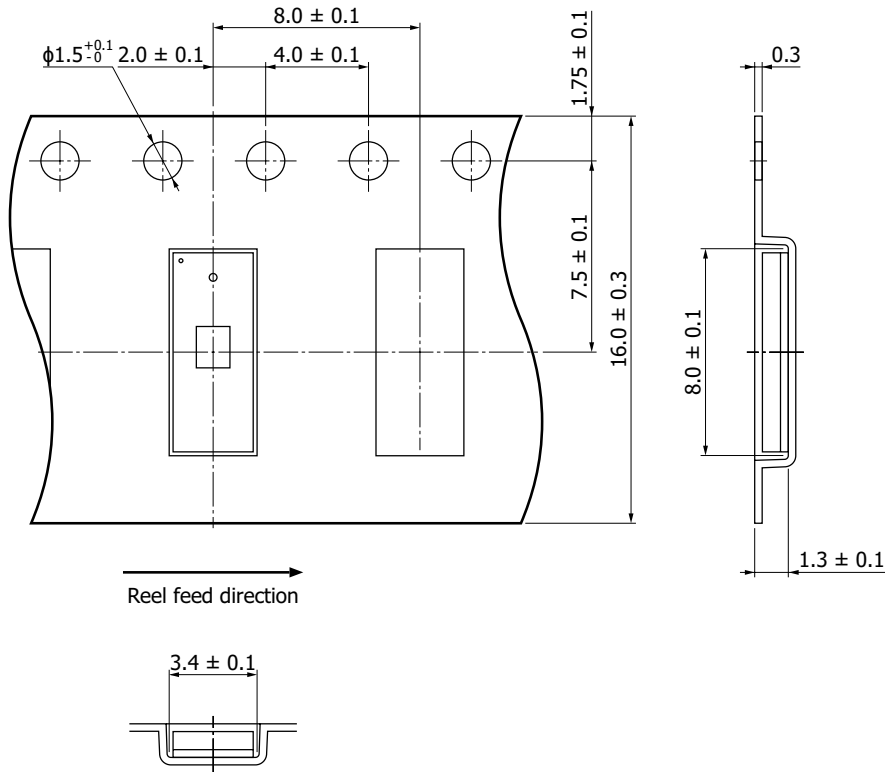

KPIC0392EA

Packing quantity

1000 pcs/reel

Packing type

Reel and desiccant in moisture-proof packaging (vacuum-sealed)

### Measured example of temperature profile with our hot-air reflow oven for product testing

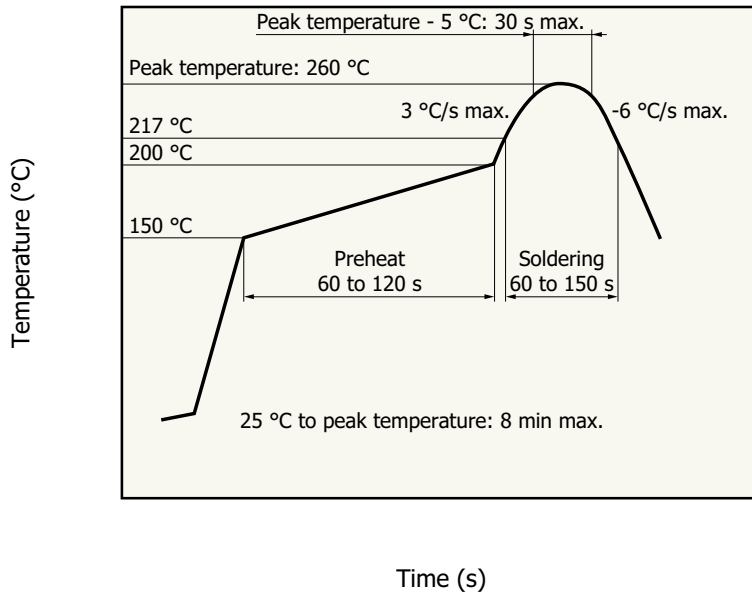

KPICC0220EA

- This product supports lead-free soldering. After unpacking, store it in an environment at a temperature of 30 °C or less and a humidity of 60% or less, and perform soldering within 168 hours.
- If it is not stored in the above environment after unpacking or more than six months has passed without unpacking, perform baking. For the baking method, see the related information "Precautions of Surface mount type products."
- The effect that the product receives during reflow soldering varies depending on the circuit board and reflow oven that are used. When you set reflow soldering conditions, check that problems do not occur in the product by testing out the conditions in advance.

### Related information

[www.hamamatsu.com/sp/ssd/doc\\_en.html](http://www.hamamatsu.com/sp/ssd/doc_en.html)

- Precautions
  - Disclaimer
  - Surface mount type products

## Evaluation kit C15285-01 for near infrared / proximity type sensor (built-in P13567-02CT)

An evaluation kit [60 mm (H) × 20 mm (V)] for understanding the operating principle of Hamamatsu's P13567-02CT and G13568-02CT near infrared / proximity type sensors is available. Contact us for detailed information.



Information described in this material is current as of June 2024.

Product specifications are subject to change without prior notice due to improvements or other reasons. This document has been carefully prepared and the information contained is believed to be accurate. In rare cases, however, there may be inaccuracies such as text errors. Before using these products, always contact us for the delivery specification sheet to check the latest specifications.

The product warranty is valid for one year after delivery and is limited to product repair or replacement for defects discovered and reported to us within that one year period. However, even if within the warranty period we accept absolutely no liability for any loss caused by natural disasters or improper product use. Copying or reprinting the contents described in this material in whole or in part is prohibited without our prior permission.

# HAMAMATSU

[www.hamamatsu.com](http://www.hamamatsu.com)

HAMAMATSU PHOTONICS K.K., Solid State Division

1126-1 Ichino-cho, Chuo-ku, Hamamatsu City, 435-8558 Japan, Telephone: (81)53-434-3311, Fax: (81)53-434-5184

U.S.A.: HAMAMATSU CORPORATION: 360 Foothill Road, Bridgewater, NJ 08807, U.S.A., Telephone: (1)908-231-0960, Fax: (1)908-231-1218

Germany: HAMAMATSU PHOTONICS DEUTSCHLAND GMBH: Arzbergerstr. 10, 82211 Herrsching am Ammersee, Germany, Telephone: (49)8152-375-0, Fax: (49)8152-265-8 E-mail: [info@hamamatsu.de](mailto:info@hamamatsu.de)

France: HAMAMATSU PHOTONICS FRANCE S.A.R.L.: 19 Rue du Saule Trapu, Parc du Moulin de Massy, 91882 Massy Cedex, France, Telephone: (33)1 69 53 71 00, Fax: (33)1 69 53 71 10 E-mail: [infos@hamamatsu.fr](mailto:infos@hamamatsu.fr)

United Kingdom: HAMAMATSU PHOTONICS UK LIMITED: 2 Howard Court, 10 Tewin Road, Welwyn Garden City, Hertfordshire, AL7 1BW, UK, Telephone: (44)1707-294888, Fax: (44)1707-325777 E-mail: [info@hamamatsu.co.uk](mailto:info@hamamatsu.co.uk)

North Europe: HAMAMATSU PHOTONICS NORDEN AB: Torshamnsgatan 35, 16440 Kista, Sweden, Telephone: (46)8-509-031-00, Fax: (46)8-509-031-01 E-mail: [info@hamamatsu.se](mailto:info@hamamatsu.se)

Italy: HAMAMATSU PHOTONICS ITALIA S.R.L.: Strada della Moia, 1 int. 6 20044 Arese (Milano), Italy, Telephone: (39)02-93 58 17 33, Fax: (39)02-93 58 17 41 E-mail: [info@hamamatsu.it](mailto:info@hamamatsu.it)

China: HAMAMATSU PHOTONICS (CHINA) CO., LTD.: 1201, Tower B, Jiaming Center, 27 Dongsanhuan Beilu, Chaoyang District, 100020 Beijing, P.R. China, Telephone: (86)10-6586-6006, Fax: (86)10-6586-2866 E-mail: [hpc@hamamatsu.com.cn](mailto:hpc@hamamatsu.com.cn)

Taiwan: HAMAMATSU PHOTONICS TAIWAN CO., LTD.: 13F-1, No.101, Section 2, Gongdao 5th Road, East Dist., Hsinchu City, 300046, Taiwan(R.O.C) Telephone: (886)3-659-0080, Fax: (886)3-659-0081 E-mail: [info@hamamatsu.com.tw](mailto:info@hamamatsu.com.tw)