

S13496-11

High sensitivity, photosensitive area with vertically long pixels (with light-shielding pixels)

The S13496-11 is a high sensitivity CMOS linear image sensor using a photosensitive area with vertically long pixels (7 × 200 μm). Other features include high sensitivity and high resistance in the UV region. The S13496-11 operates from a single 5 V supply making it suitable for use in low cost spectrometers.

Features

- Pixel size: 7 × 200 μm
- Number of effective pixels: 4008, 20 pixels on each end: optical black
- Effective photosensitive area length: 28.056 mm
- High sensitivity: 650 V/(lx·s)
- High sensitivity in UV to NIR region (spectral response range: 200 to 1000 nm)
- Simultaneous charge integration for all pixels
- Variable integration time function (electronic shutter function)
- 5 V single power supply operation
- Built-in timing generator allows operation with only start and clock pulse inputs
- Video data rate: 10 MHz max.

Applications

- Spectrometers
- Position detection
- Image reading
- Encoders

Structure

Parameter	Specification	Unit
Number of pixels	4096	-
Pixel size	7 × 200	μm
Photosensitive area length	28.672	mm
Number of effective pixels	4008	-
Package	LCP (liquid crystal polymer)	-
Window material	Quartz	-

Absolute maximum ratings

Parameter	Symbol	Condition	Value	Unit
Supply voltage	Vdd	Ta=25 °C	-0.3 to +6	V
Clock pulse voltage	V(CLK)	Ta=25 °C	-0.3 to +6	V
Start pulse voltage	V(ST)	Ta=25 °C	-0.3 to +6	V
Operating temperature	Topr	No dew condensation*1	-40 to +65	°C
Storage temperature	Tstg	No dew condensation*1	-40 to +65	°C

*1: When there is a temperature difference between a product and the surrounding area in high humidity environments, dew condensation may occur on the product surface. Dew condensation on the product may cause deterioration in characteristics and reliability.

Note: Exceeding the absolute maximum ratings even momentarily may cause a drop in product quality. Always be sure to use the product within the absolute maximum ratings.

➤ Recommended terminal voltage (Ta=25 °C)

Parameter	Symbol	Min.	Typ.	Max.	Unit
Supply voltage	Vdd	4.75	5	5.25	V
Clock pulse voltage	High level	3	Vdd	Vdd + 0.25	V
	Low level	0	-	0.3	V
Start pulse voltage	High level	3	Vdd	Vdd + 0.25	V
	Low level	0	-	0.3	V

➤ Input terminal capacitance (Ta=25 °C, Vdd=5 V)

Parameter	Symbol	Min.	Typ.	Max.	Unit
Clock pulse input terminal capacitance	C(CLK)	-	5	-	pF
Start pulse input terminal capacitance	C(ST)	-	5	-	pF

➤ Electrical characteristics [Ta=25 °C, Vdd=5 V, V(CLK)=V(ST)=5 V]

Parameter	Symbol	Min.	Typ.	Max.	Unit
Clock pulse frequency	f(CLK)	200 k	5 M	10 M	Hz
Data rate	DR	-	f(CLK)	-	Hz
Output impedance	Zo	70	-	260	Ω
Current consumption*2 *3	Ic	20	40	60	mA

*2: f(CLK)=10 MHz

*3: Current consumption increases as the clock pulse frequency increases. The current consumption is 10 mA typ. at f(CLK)=200 kHz.

➤ Electrical and optical characteristics [Ta=25 °C, Vdd=5 V, V(CLK)=V(ST)=5 V, f(CLK)=10 MHz]

Parameter	Symbol	Min.	Typ.	Max.	Unit
Spectral response range	λ	200 to 1000			nm
Peak sensitivity wavelength	λp	-	700	-	nm
Photosensitivity*4	S	-	650	-	V/(lx·s)
Conversion efficiency*5	CE	-	20	-	μV/e-
Dark output voltage*6	Vd	0	0.1	2.0	mV
Saturation output voltage*7 *8	Vsat	1.5	2.0	2.5	V
Readout noise	Nread	0.1	0.4	1.2	mV rms
Dynamic range 1*9	Drange1	-	5000	-	times
Dynamic range 2*10	Drange2	-	20000	-	times
Output offset voltage	Voffset	0.3	0.6	0.9	V
Photoresponse nonuniformity*4 *11	PRNU	-	±2	±10	%
Image lag*12	Lag	-	-	0.1	%

*4: Measured with a tungsten lamp of 2856 K

*5: Output voltage generated per one electron

*6: Integration time=10 ms

*7: Difference from Voffset

*8: CDS (correlated double sampling) is done inside the image sensor in order to reduce noise. The final output is the difference between the output when the photosensitive area is put in the reset state, and the light output integrated in the photosensitive area. If used in an over-saturated state, the light output component may get mixed into the output when the photosensitive area is put in the reset state, causing the final output to decrease.

*9: Drange1= Vsat/Nread

*10: Drange2= Vsat/Vd

Integration time=10 ms

Dark output voltage is proportional to the integration time and so the shorter the integration time, the wider the dynamic range.

*11: Photoresponse nonuniformity (PRNU) is the output nonuniformity that occurs when the entire photosensitive area is uniformly illuminated by light which is 50% of the saturation exposure level. PRNU is measured using 4002 pixels excluding 3 pixels each at both ends, and is defined as follows:

$$PRNU = \frac{\Delta X}{X} \times 100 (\%)$$

X: average output of all pixels, ΔX: difference between X and maximum output or minimum output

*12: Signal components of the preceding line data that still remain even after the data is read out in a saturation output state.

Image lag increases when the output exceeds the saturation output voltage.

Spectral response (typical example)

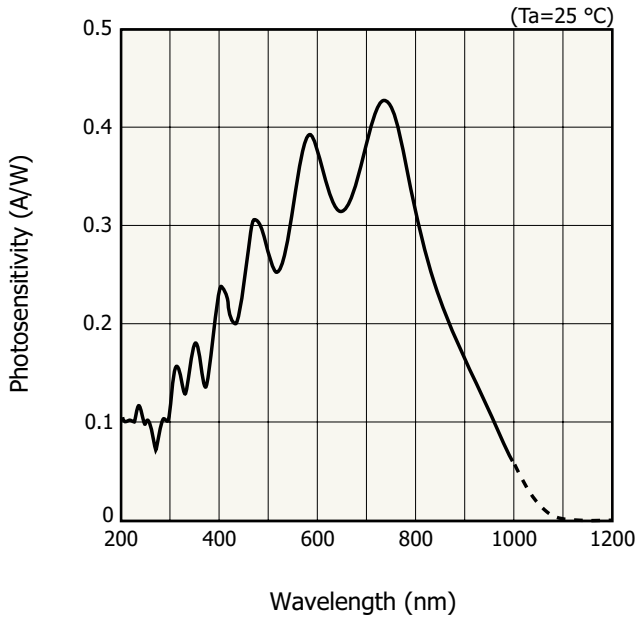

Spectral response in UV region (typical example)

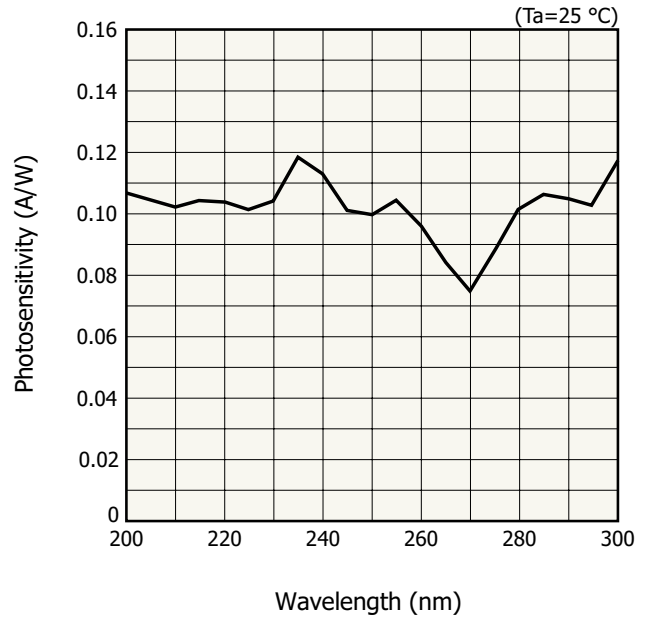

Block diagram

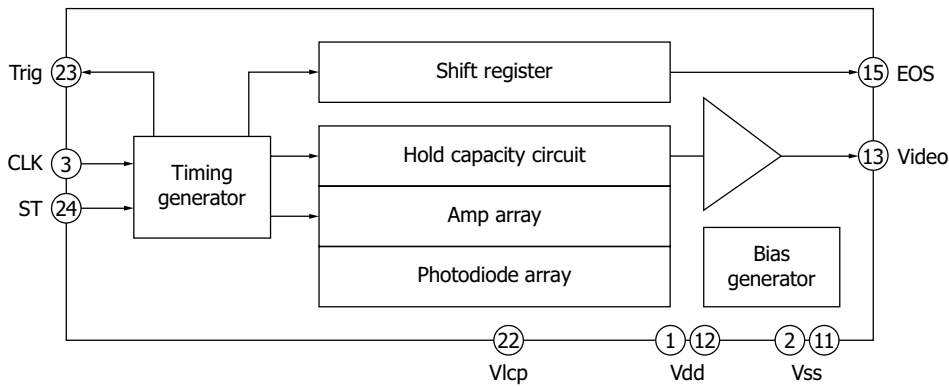

Output waveform of one pixel

The timing for acquiring the Video signal is synchronized with the rising edge of a trigger pulse (See red arrow below.).

$f(\text{CLK})=\text{DR}=10\text{ MHz}$

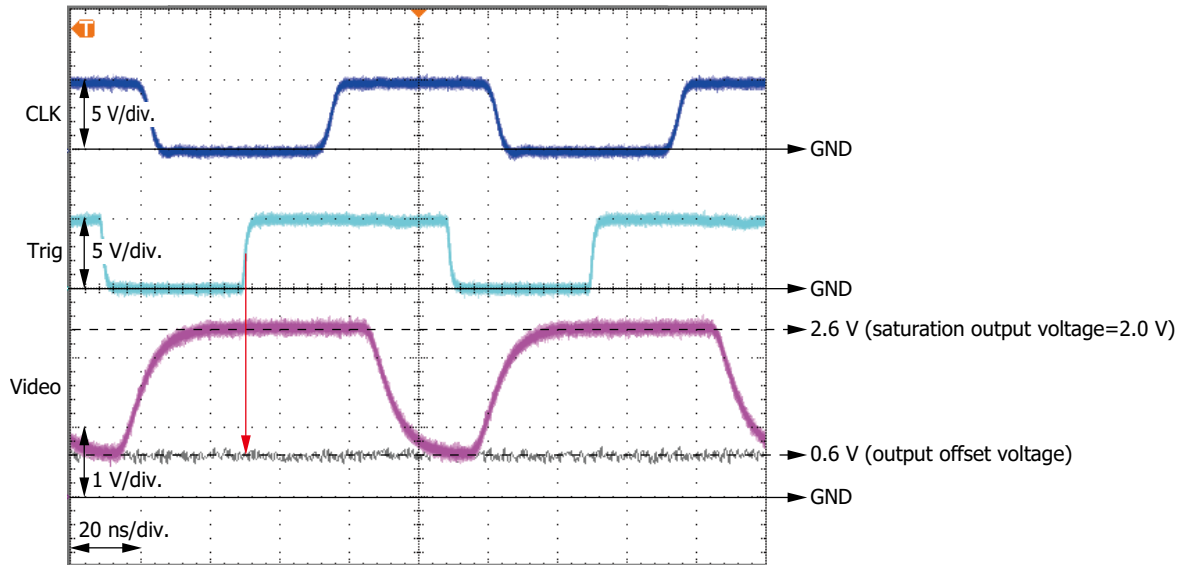

$f(\text{CLK})=\text{DR}=1\text{ MHz}$

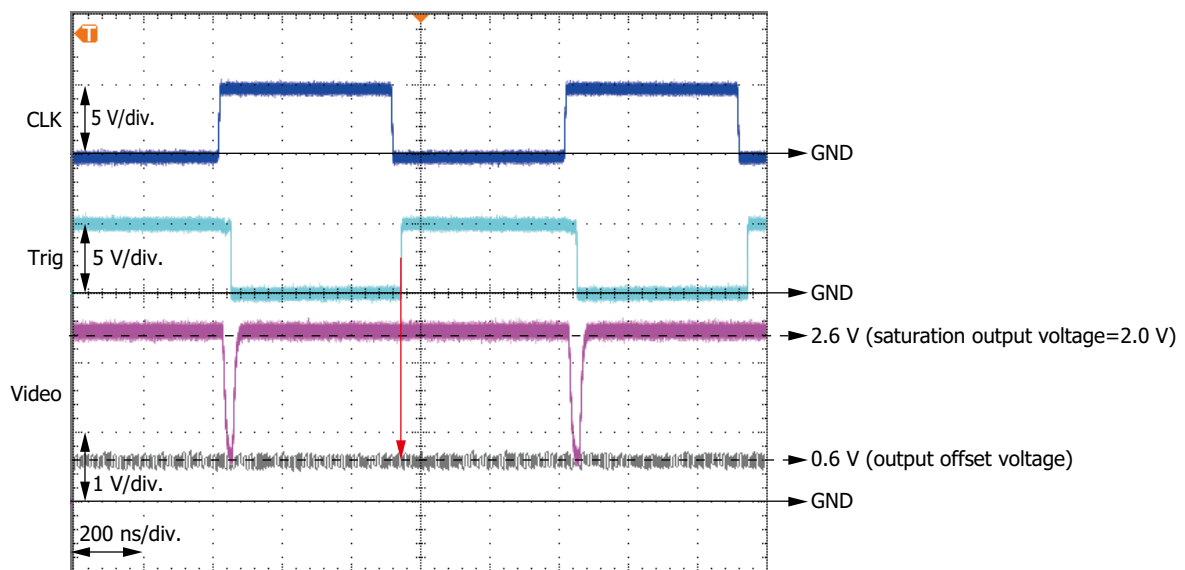

Timing chart

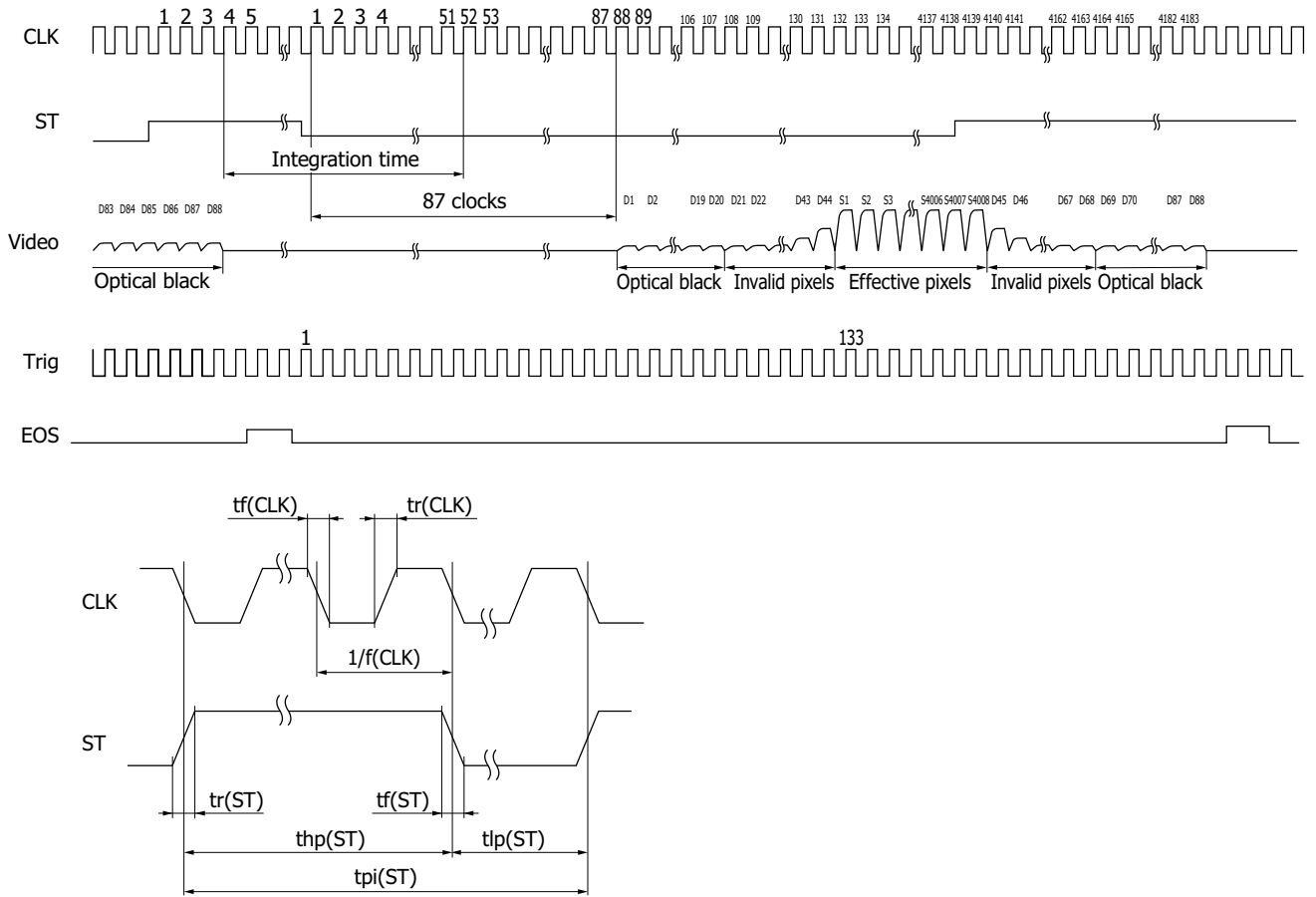

KMPDC0656EA

Parameter	Symbol	Min.	Typ.	Max.	Unit
Start pulse width interval ^{*13}	t _{pi} (ST)	106/f(CLK)	-	-	s
Start pulse high period ^{*13 *14}	t _{hp} (ST)	6/f(CLK)	-	-	s
Start pulse low period	t _{lp} (ST)	100/f(CLK)	-	-	s
Start pulse rise and fall times	t _r (ST), t _f (ST)	0	10	30	ns
Clock pulse duty	-	45	50	55	%
Clock pulse rise and fall times	t _r (CLK), t _f (CLK)	0	10	30	ns

*13: Dark output increases if the start pulse period or the start pulse high period is lengthened.

*14: The integration time equals the high period of ST plus 48 CLK cycles.

The shift register starts operation at the rising edge of CLK immediately after ST goes low.

The integration time can be changed by changing the ratio of the high and low periods of ST.

If the first Trig pulse after ST goes low is counted as the first pulse, the Video signal is acquired at the rising edge of the 89th Trig pulse.

Note: After power-on, do not float the ST and CLK input terminals. Instead, set them to high level or low level. Immediately after power-on, the signal in the sensor becomes undefined. Do not use invalid data from the first scan. Instead, use valid data from the second scan onwards.

Operation example

- When outputting from all 4096 pixels

This example assumes that the clock pulse frequency is maximized (data rate is also maximized), the time of one scan is minimized, and the integration time is maximized

Clock pulse frequency = Data rate = 10 MHz

Start pulse cycle = $4188/f(\text{CLK}) = 4188/10 \text{ MHz} = 418.8 \mu\text{s}$

High period of start pulse = Start pulse cycle - Start pulse's low period min.

$$= 4188/f(\text{CLK}) - 100/f(\text{CLK}) = 4188/10 \text{ MHz} - 100/10 \text{ MHz} = 408.8 \mu\text{s}$$

Integration time is equal to the high period of start pulse + 48 cycles of clock pulses, so it will be $408.8 + 4.8 = 413.6 \mu\text{s}$.

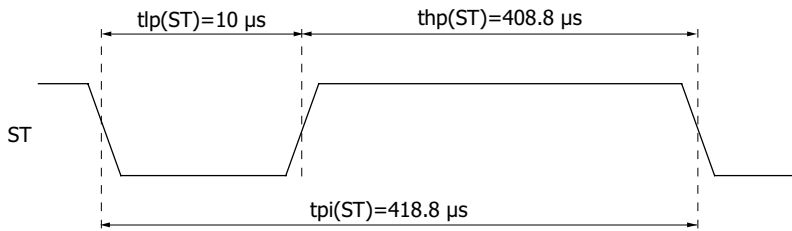

KMPDC0481EA

Dimensional outline (unit: mm)

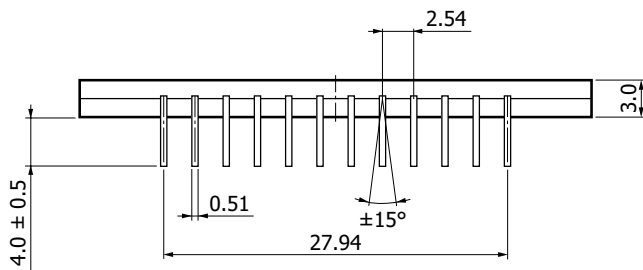
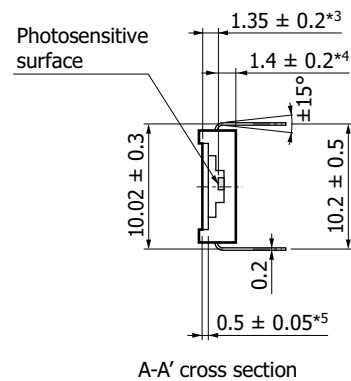
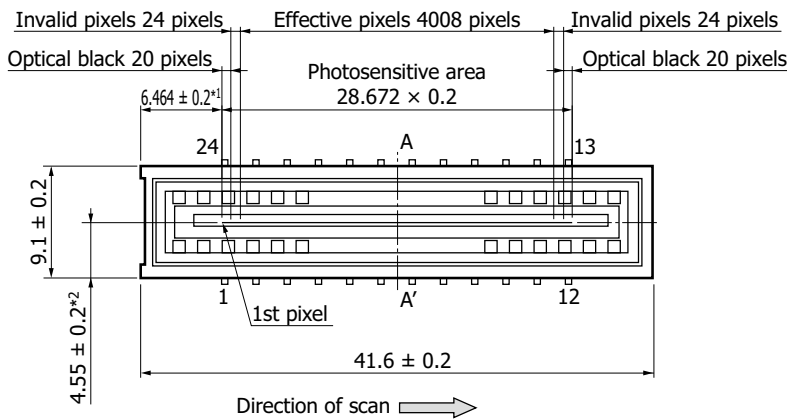

Tolerance unless otherwise noted: ± 0.1

- *1: Distance from package edge to photosensitive area edge
- *2: Distance from package edge to photosensitive area center
- *3: Distance from glass surface to photosensitive surface
- *4: Distance from package bottom to photosensitive surface
- *5: Glass thickness

KMPDA0582EA

Pin connections

Pin no.	Symbol	I/O	Description	Pin no.	Symbol	I/O	Description
1	Vdd	I	Supply voltage	13	Video	O	Video signal ^{*15}
2	Vss	-	GND	14	NC	-	No connection
3	CLK	I	Clock pulse	15	EOS	O	End of scan
4	NC	-	No connection	16	NC	-	No connection
5	NC	-	No connection	17	NC	-	No connection
6	NC	-	No connection	18	NC	-	No connection
7	NC	-	No connection	19	NC	-	No connection
8	NC	-	No connection	20	NC	-	No connection
9	NC	-	No connection	21	NC	-	No connection
10	NC	-	No connection	22	Vlcp	-	Bias voltage for negative voltage circuit ^{*16}
11	Vss	-	GND	23	Trig	O	Trigger pulse for video signal acquisition ^{*17}
12	Vdd	I	Supply voltage	24	ST	I	Start pulse

*15: Connect a buffer amplifier for impedance conversion to the video output terminal so as to minimize the current flow. As the buffer amplifier, use a high input impedance operational amplifier with JFET or CMOS input.

*16: Approximately -1.5 V generated by the negative voltage circuit inside the chip is output to the terminal. To maintain the voltage, insert a capacitor around 1 μ F between Vlcp and GND.

*17: We recommend capturing video signal using the trigger pulse output from Trig.

Note: Leave the "NC" terminals open and do not connect them to GND.

Recommended soldering conditions

Parameter	Specification	Note
Soldering temperature	260 °C max. (5 seconds or less)	

Note: When you set soldering conditions, check that problems do not occur in the product by testing out the conditions in advance.

Precautions

(1) Electrostatic countermeasures

This device has a built-in protection circuit against static electrical charges. However, to prevent destroying the device with electrostatic charges, take countermeasures such as grounding yourself, the workbench and tools to prevent static discharges. Also protect this device from surge voltages which might be caused by peripheral equipment.

(2) Light input window

If dust or dirt gets on the light input window, it will show up as black blemishes on the image. When cleaning, avoid rubbing the window surface with dry cloth or dry cotton swab, since doing so may generate static electricity. Use soft cloth, paper or a cotton swab moistened with alcohol to wipe dust and dirt off the window surface. Then blow compressed air onto the window surface so that no spot or stain remains.

(3) UV exposure

This device is designed to suppress performance deterioration due to UV exposure. Even so, avoid unnecessary UV exposure to the device. Also, be careful not to allow UV light to strike the cemented portion of the glass.

Application circuit example

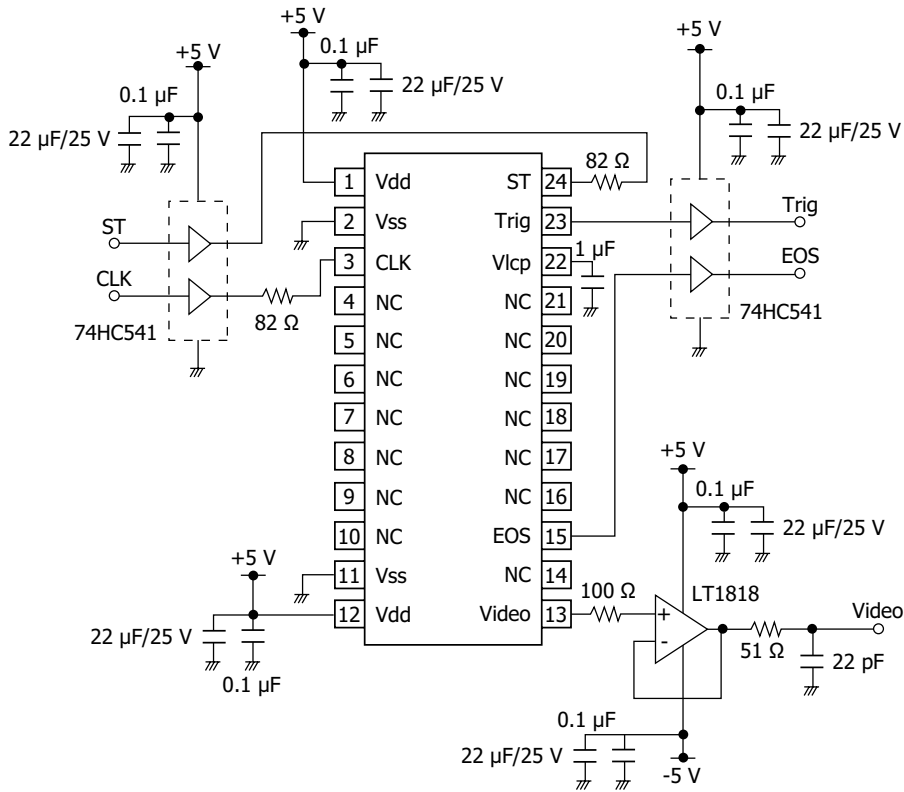

KMPDC0564EA

Related information

www.hamamatsu.com/sp/ssd/doc_en.html

- Precautions
 - Disclaimer
 - Image sensors
- Technical note
 - CMOS linear image sensors

Driver circuit for CMOS linear image sensors C16605 [sold separately]

The driver circuit for CMOS linear image sensor S13496-11 is available (sold separately). It can be used for spectrometers, etc. combining with the CMOS linear image sensor. Contact us for detailed information.

Features

- Built-in 16-bit A/D converter
- Interface to computer: USB 2.0
- Power supply: USB bus power operation



Information described in this material is current as of April 2024.

Product specifications are subject to change without prior notice due to improvements or other reasons. This document has been carefully prepared and the information contained is believed to be accurate. In rare cases, however, there may be inaccuracies such as text errors. Before using these products, always contact us for the delivery specification sheet to check the latest specifications.

The product warranty is valid for one year after delivery and is limited to product repair or replacement for defects discovered and reported to us within that one year period. However, even if within the warranty period we accept absolutely no liability for any loss caused by natural disasters or improper product use. Copying or reprinting the contents described in this material in whole or in part is prohibited without our prior permission.

HAMAMATSU

www.hamamatsu.com

HAMAMATSU PHOTONICS K.K., Solid State Division

1126-1 Ichino-cho, Chuo-ku, Hamamatsu City, 435-8558 Japan, Telephone: (81)53-434-3311, Fax: (81)53-434-5184

U.S.A.: HAMAMATSU CORPORATION: 360 Foothill Road, Bridgewater, NJ 08807, U.S.A., Telephone: (1)908-231-0960, Fax: (1)908-231-1218

Germany: HAMAMATSU PHOTONICS DEUTSCHLAND GMBH: Arzbergerstr. 10, 82211 Herrsching am Ammersee, Germany, Telephone: (49)8152-375-0, Fax: (49)8152-265-8 E-mail: info@hamamatsu.de

France: HAMAMATSU PHOTONICS FRANCE S.A.R.L.: 19 Rue du Saule Trapu, Parc du Moulin de Massy, 91882 Massy Cedex, France, Telephone: (33)1 69 53 71 00, Fax: (33)1 69 53 71 10 E-mail: infos@hamamatsu.fr

United Kingdom: HAMAMATSU PHOTONICS UK LIMITED: 2 Howard Court, 10 Tewin Road, Welwyn Garden City, Hertfordshire, AL7 1BW, UK, Telephone: (44)1707-294888, Fax: (44)1707-325777 E-mail: info@hamamatsu.co.uk

North Europe: HAMAMATSU PHOTONICS NORDEN AB: Torshamnsgatan 35, 16440 Kista, Sweden, Telephone: (46)8-509-031-00, Fax: (46)8-509-031-01 E-mail: info@hamamatsu.se

Italy: HAMAMATSU PHOTONICS ITALIA S.R.L.: Strada della Moia, 1 int. 6 20044 Arese (Milano), Italy, Telephone: (39)02-93 58 17 33, Fax: (39)02-93 58 17 41 E-mail: info@hamamatsu.it

China: HAMAMATSU PHOTONICS (CHINA) CO., LTD.: 1201, Tower B, Jiaming Center, 27 Dongsanhuan Beilu, Chaoyang District, 100020 Beijing, P.R. China, Telephone: (86)10-6586-6006, Fax: (86)10-6586-2866 E-mail: hpc@hamamatsu.com.cn

Taiwan: HAMAMATSU PHOTONICS TAIWAN CO., LTD.: 13F-1, No.101, Section 2, Gongdao 5th Road, East Dist., Hsinchu City, 300046, Taiwan(R.O.C) Telephone: (886)3-659-0080, Fax: (886)3-659-0081 E-mail: info@hamamatsu.com.tw