

# Balanced detectors

These are differential amplification type photoelectric conversion modules containing two photodiodes with uniform characteristics. The photodiodes are connected in a direction that cancels out the photocurrent of each photodiode. This configuration cancels out the common mode noise of the two incident light rays. The minute difference in light levels is treated as a displacement signal, converted into an electrical signal, and output. We offer a built-in InGaAs PIN photodiode type covering a spectral range of 0.9 to 1.7  $\mu\text{m}$ .

## 1 Features

- ▶ Employs our unique (patented) structure that reduces multiple reflections at the incident light wavelength of 1.0  $\mu\text{m}$  or 1.3  $\mu\text{m}$
- ▶ Input section: FC receptacle (APC polished)  
A single-mode fiber with an FC connector can be connected.
- ▶ Output section: SMA receptacle
- ▶ Compact

## 2 Structure

The balanced detector has two inputs: (INPUT +/-), which receive signal light and reference light respectively. The differential signal of the two incident lights is output from the OUT terminal. The Monitor terminals (Mon +/-) output electrical signals, produced by conversion of the light level of light, which is incident from the optical fibers connected to the INPUT +/- terminals.

It employs a structure that reduces multiple reflections of incident light, which reduces light interference that would be caused by such reflections. With customer order products, it is possible to reduce reflections at specific wavelengths.

[Figure 1] Block diagram

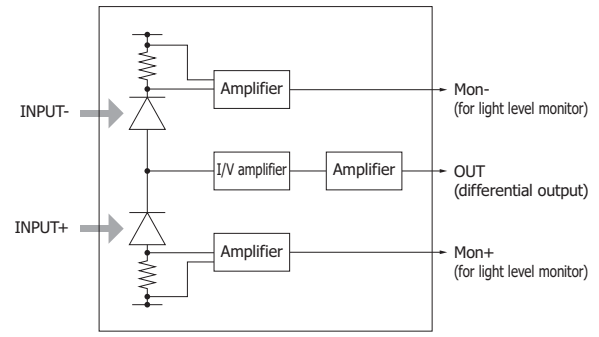

KACCC0761EB

## 3 Characteristics

[Table 2] Specifications

Parameter	Specification
Photosensor	InGaAs PIN photodiode
Spectral response range	0.9 to 1.7 $\mu\text{m}$
Output impedance	50 $\Omega$
Input section	FC receptacle (APC polished)
Output section	SMA receptacle
Supply voltage	$\pm 12$ V (200 mA)

[Table 1] Hamamatsu balanced detectors

Type no.	Optimal wavelength band $\lambda_{op}$ ( $\mu\text{m}$ )	Cutoff frequency $f_c$ -3 dB (MHz)		Common-mode rejection ratio CMRR (dB)	Conversion impedance $Z_t$ (V/A)	
		OUT terminal	Monitor terminal		OUT terminal	Monitor terminal
C12668-01	1.0	200	0.1	35	$3 \times 10^4$	$1 \times 10^4$
C12668-02	1.3					
C12668-03	1.0	400	1	30	$1 \times 10^4$	
C12668-04	1.3					

[Figure 2] Frequency characteristics  
(measured with network analyzer, typical example)

(a) C12668-01/02

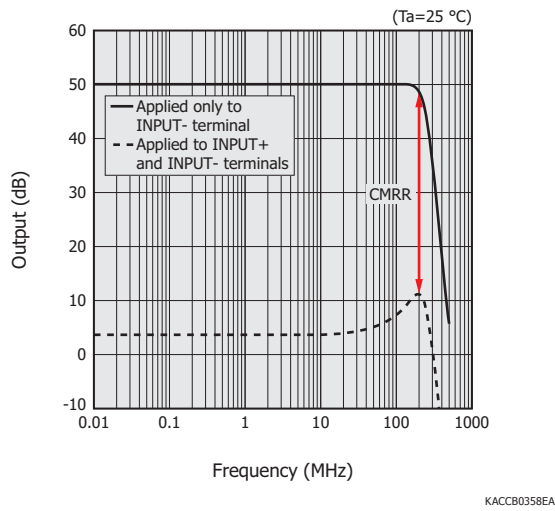

(b) C12668-03/04

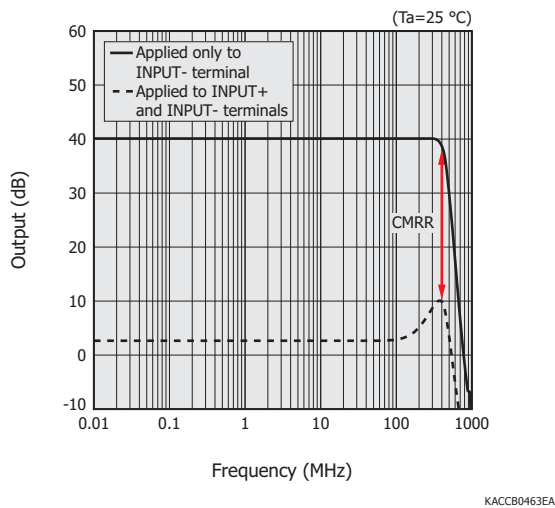

## 4 How to use

Using the supplied power cable, connect the balanced detector to a power supply. Use a dual power supply that can output  $\pm 200\text{ mA}$  current.

For optical input, two single mode fibers with FC connectors (APC polished) are used to apply a signal light and a reference light. If the light level and phase of these two incident lights are uniform, the output would be zero. If there is a difference in light level and phase between the signal light and reference light, the difference becomes the displacement signal, and this signal is converted into an electric signal, and output from the output terminal (SMA receptacle). Note that since the output impedance is  $50\ \Omega$ , you will need to set the input impedance of the connected measuring device to  $50\ \Omega$ . The length of the output coaxial cable should be three meters or less. The monitor terminal outputs electrical signals converted from the light

level of the two incident lights, so it can be used to adjust the light level of the incident light.

[Figure 3] Connection example

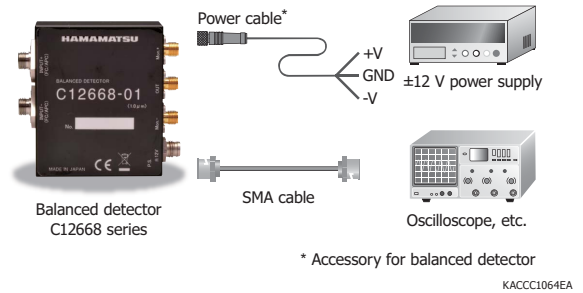

[Figure 4] I/O example of balanced detector

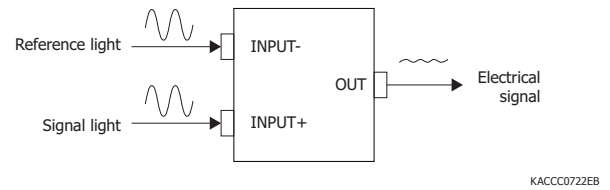

## 5 Applications

The balanced detector can be used in various measurement and analytical instruments that use optical interference signals. It is also used for medical equipment such as an optical coherence tomography (OCT), which captures images of internal structure with high resolution and high speed.

[Figure 5] OCT

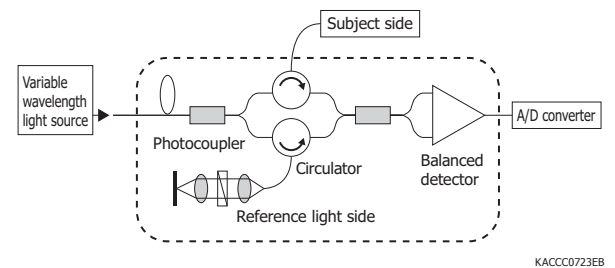

Information described in this material is current as of December 2020.

Product specifications are subject to change without prior notice due to improvements or other reasons. This document has been carefully prepared and the information contained is believed to be accurate. In rare cases, however, there may be inaccuracies such as text errors. Before using these products, always contact us for the delivery specification sheet to check the latest specifications.

The product warranty is valid for one year after delivery and is limited to product repair or replacement for defects discovered and reported to us within that one year period. However, even if within the warranty period we accept absolutely no liability for any loss caused by natural disasters or improper product use. Copying or reprinting the contents described in this material in whole or in part is prohibited without our prior permission.

# HAMAMATSU

[www.hamamatsu.com](http://www.hamamatsu.com)

HAMAMATSU PHOTONICS K.K., Solid State Division

1126-1 Ichino-cho, Higashi-ku, Hamamatsu City, 435-8558 Japan, Telephone: (81)53-434-3311, Fax: (81)53-434-5184

U.S.A.: Hamamatsu Corporation, 360 Foothill Road, Bridgewater, N.J. 08807, U.S.A., Telephone: (1)908-231-0960, Fax: (1)908-231-1218, E-mail: [usa@hamamatsu.com](mailto:usa@hamamatsu.com)

Germany: Hamamatsu Photonics Deutschland GmbH: Arzbergerstr. 10, D-82211 Herrsching am Ammersee, Germany, Telephone: (49)8152-375-0, Fax: (49)8152-265-8, E-mail: [info@hamamatsu.de](mailto:info@hamamatsu.de)

France: Hamamatsu Photonics France S.A.R.L.: 19, Rue du Saule Trapu, Parc du Moulin de Massy, 91882 Massy Cedex, France, Telephone: (33)1 69 53 71 00, Fax: (33)1 69 53 71 10, E-mail: [infos@hamamatsu.fr](mailto:infos@hamamatsu.fr)

United Kingdom: Hamamatsu Photonics UK Limited: 2 Howard Court, 10 Tewin Road, Welwyn Garden City, Hertfordshire AL7 1BW, United Kingdom, Telephone: (44)1707-294888, Fax: (44)1707-325777, E-mail: [info@hamamatsu.co.uk](mailto:info@hamamatsu.co.uk)

North Europe: Hamamatsu Photonics Norden AB: Torshamnsgatan 35 16440 Kista, Sweden, Telephone: (46)8-509 031 00, Fax: (46)8-509 031 01, E-mail: [info@hamamatsu.se](mailto:info@hamamatsu.se)

Italy: Hamamatsu Photonics Italia S.r.l.: Strada della Moia, 1 int. 6, 20020 Arese (Milano), Italy, Telephone: (39)02-93 58 17 33, Fax: (39)02-93 58 17 41, E-mail: [info@hamamatsu.it](mailto:info@hamamatsu.it)

China: Hamamatsu Photonics (China) Co., Ltd.: B1201, Jiaming Center, No.27 Dongsanhuan Beilu, Chaoyang District, 100020 Beijing, P.R.China, Telephone: (86)10-6586-6006, Fax: (86)10-6586-2866, E-mail: [hpc@hamamatsu.com.cn](mailto:hpc@hamamatsu.com.cn)

Taiwan: Hamamatsu Photonics Taiwan Co., Ltd.: 8F-3, No. 158, Section2, Gongdao 5th Road, East District, Hsinchu, 300, Taiwan R.O.C. Telephone: (886)3-659-0080, Fax: (886)3-659-0081, E-mail: [info@hamamatsu.com.tw](mailto:info@hamamatsu.com.tw)

Cat. No. KACC9016E01 Dec. 2020 DN