

InGaAs area image sensor

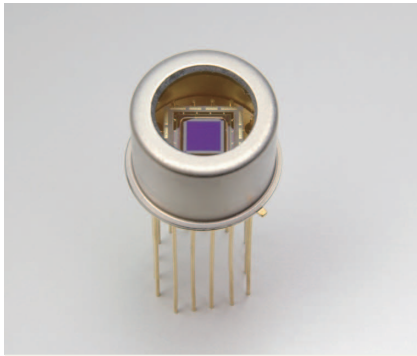

G12460-0606S

Image sensor with 64 × 64 pixels developed for two-dimensional infrared imaging

The G12460-0606S has a hybrid structure consisting of a CMOS readout circuit (ROIC: readout integrated circuit) and back-illuminated InGaAs photodiodes. Each pixel is made up of an InGaAs photodiode and a ROIC electrically connected by an indium bump. A timing generator in the ROIC provides an analog video output and AD-TRIG output which are easily obtained by just supplying a master clock (MCLK) and master start pulse (MSP) from external digital inputs.

The G12460-0606S has 64×64 pixels arrayed at a 50 μm pitch and their signals are read out from a single video line. Light incident on the InGaAs photodiodes is converted into electrical signals which are then input to the ROIC through indium bumps. Electrical signals in the ROIC are converted into voltage signals by charge amplifiers and then sequentially output from the video line by the shift register. The G12460-0606S is hermetically sealed in a TO-8 package together with a one-stage thermoelectric cooler to deliver low-cost yet highly stable operation.

Features

- Spectral response range: 1.12 to 1.9 μm
- Excellent linearity by offset compensation
- High sensitivity: 1600 nV/e⁻
- Simultaneous charge integration for all pixels (global shutter mode)
- Simple operation (built-in timing generator)
- One-stage TE-cooled
- Low cost

Applications

- Thermal imaging monitor
- Laser beam profiler
- Near infrared image detection
- Foreign object detection

Block diagram

A sequence of operation of the readout circuit is described below. In the readout circuit, the charge amplifier output voltage is sampled and held simultaneously at all pixels during the integration time determined by the low period of the master start pulse (MSP) which is as a frame scan signal. Then the pixels are scanned and their video signals are output.

Pixel scanning starts from the starting point at the upper left in the right figure. The vertical shift register scans from top to bottom in the right figure while sequentially selecting each row.

For each pixel on the selected row, the following operations are performed:

- ① Transfers the sampled and held optical signal information to the signal processing circuit as a signal voltage.
- ② Resets the amplifier in each pixel after having transferred the signal voltage and transfers the reset voltage to the signal processing circuit.
- ③ The signal processing circuit samples and holds the signal voltage ① and reset voltage ②.
- ④ The horizontal shift register scans from left to right in the right figure, and the voltage difference between ① and ② is calculated in the offset compensation circuit. This eliminates the amplifier offset voltage in each pixel. The voltage difference between ① and ② is output as the output signal in the form of serial data.

The vertical shift register then selects the next row and repeats the operations from ① to ④. After the vertical shift register advances to the 64th row, the MSP, which is a frame scan signal, goes high. After that, when the MSP goes high and then low, the reset switches for all pixels are simultaneously released and the next frame integration begins.

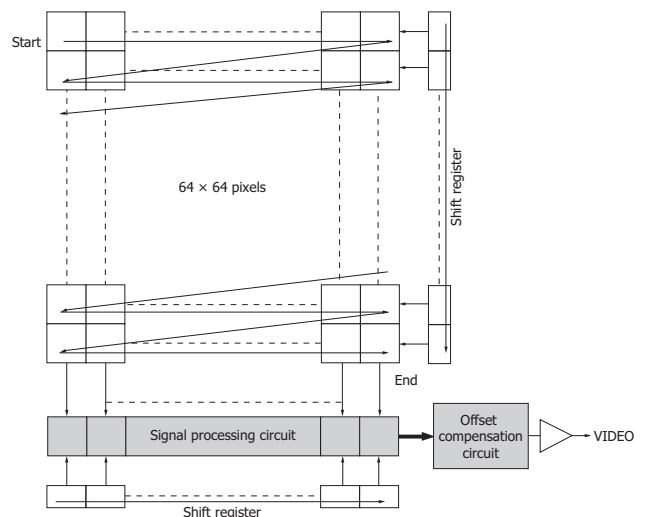

KMIRC0043EA

Element structure

Parameter	Specification	Unit
Image size	3.2 × 3.2	mm
Cooling	One-stage TE-cooled	-
Number of total pixels	4096 (64 × 64)	pixels
Number of effective pixels	4096 (64 × 64)	pixels
Pixel size	50 × 50	μm
Pixel pitch	50	μm
Package	TO-8 16-pin metal (refer to dimensional outline)	-
Window	Anti-reflective coating borosilicate glass	-

Absolute maximum ratings

Parameter	Symbol	Value	Unit
Supply voltage	Vdd	-0.3 to +5.5	V
Clock pulse voltage	V(MCLK)	Vdd + 0.5	V
Operating temperature	Topr	-10 to +60	°C
Storage temperature	Tstg	-20 to +70	°C
TE-cooler allowable current	Ic	1.3	A
TE-cooler allowable voltage	Vc	1.9	V
Thermistor power dissipation	Pth	0.2	mW

Note: Exceeding the absolute maximum ratings even momentarily may cause a drop in product quality. Always be sure to use the product within the absolute maximum ratings.

Electrical and optical characteristics (Ta=25 °C, Td=0 °C, Vdd=5 V, PD_bias=4.5 V)

Parameter	Symbol	Condition	Min.	Typ.	Max.	Unit
Spectral response range	λ		-	1.12 to 1.9	-	μm
Peak sensitivity wavelength	λp		-	1.75	-	μm
Photosensitivity	S	λ=λp	1.0	1.1	-	A/W
Conversion efficiency	CE		-	1600	-	nV/e ⁻
Saturation charge	Qsat		-	1.3	-	Me ⁻
Saturation output voltage	Vsat	After subtracting dark output	1.5	2.0	-	V
Photoresponse nonuniformity*1	PRNU	After subtracting dark output, Integration time: 1 ms	-	±10	±20	%
Dark voltage	Vd	Integration time: 2 ms	1.0	1.3	1.6	V
Dark current	Id		-	8	20	pA
Dark output nonuniformity	DSNU	Integration time: 2 ms	-	±0.2	±0.5	V
Readout noise	Nr	Integration time: 0.1 ms	-	800	1500	μV rms
Dynamic range	DR		-	2500	-	-
Defective pixel*2	-		-	-	1	%

*1: Measured at one-half of the saturation, excluding first and last pixels on each row

*2: Pixels with photoresponse nonuniformity (integration time: 1 ms), readout noise, dark current, dark output, DSNU, or saturation output voltage higher than the maximum value

One or less cluster of four or more contiguous defective pixels

<Examples of four contiguous defective pixels>

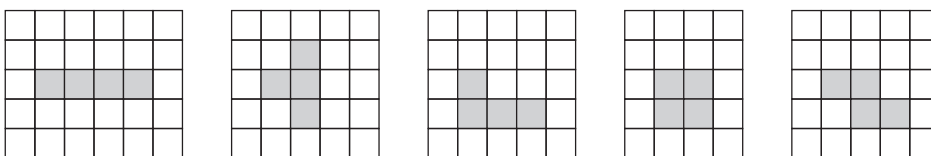

Normal pixel

Defective pixel

KMIRC00606B

Electrical characteristics (Ta=25 °C)

Parameter	Symbol	Min.	Typ.	Max.	Unit
Supply voltage	Vdd	4.9	5	5.1	V
Supply current	I(Vdd)	-	30	60	mA
Ground	Vss	-	0	-	V
Element bias	PD_bias	4.4	4.5	4.6	V
Element bias current	I(PDbias)	-	-	1	mA
Video output voltage	High	VH	3.2	-	V
	Low	VL	1.2	-	
Clock frequency	f	-	-	40	MHz
Video data rate	fV	-	f/8	-	MHz
Thermistor resistance	Rth	8.2	9	9.8	kΩ

Equivalent circuit

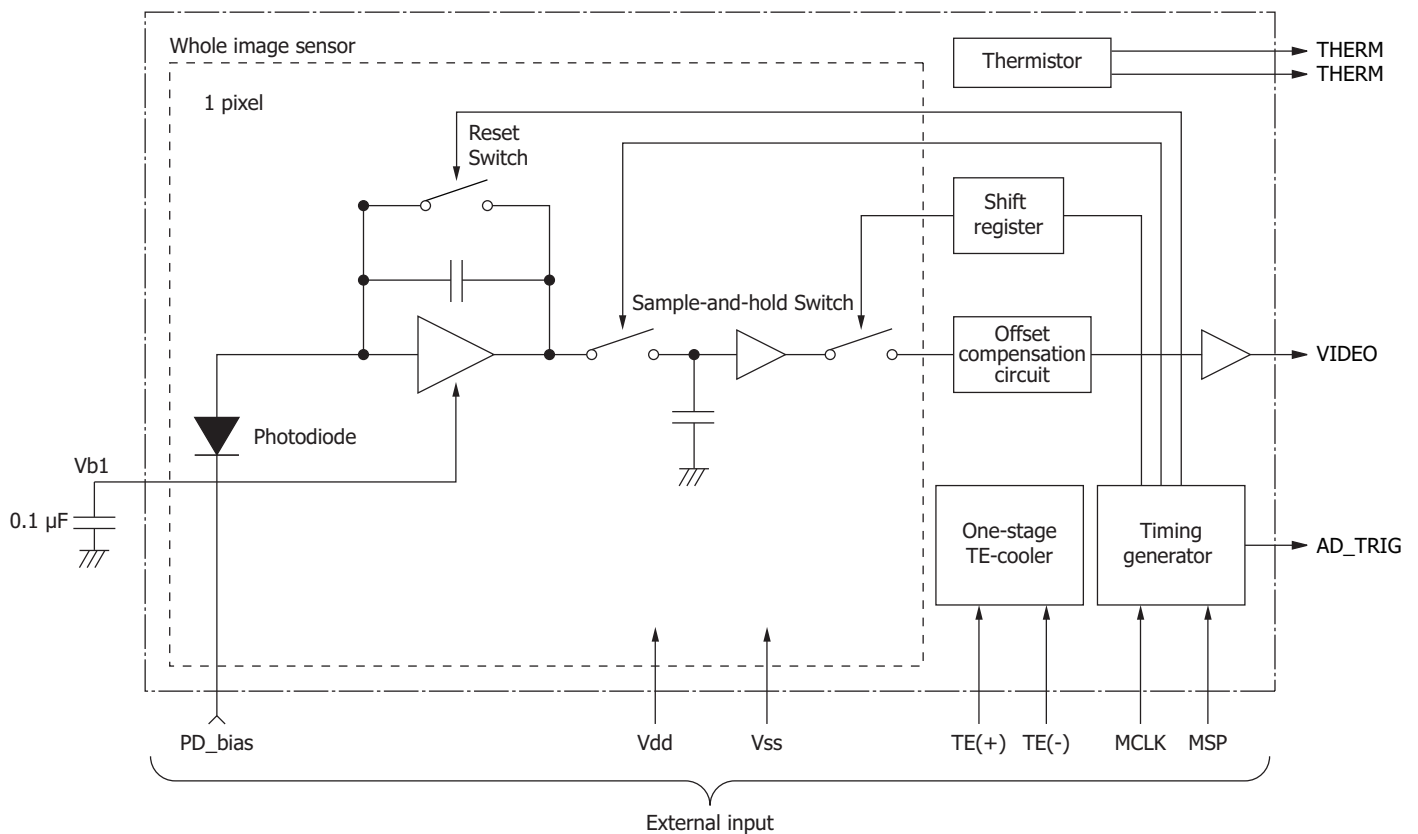

KMIRC0063ED

Connection example

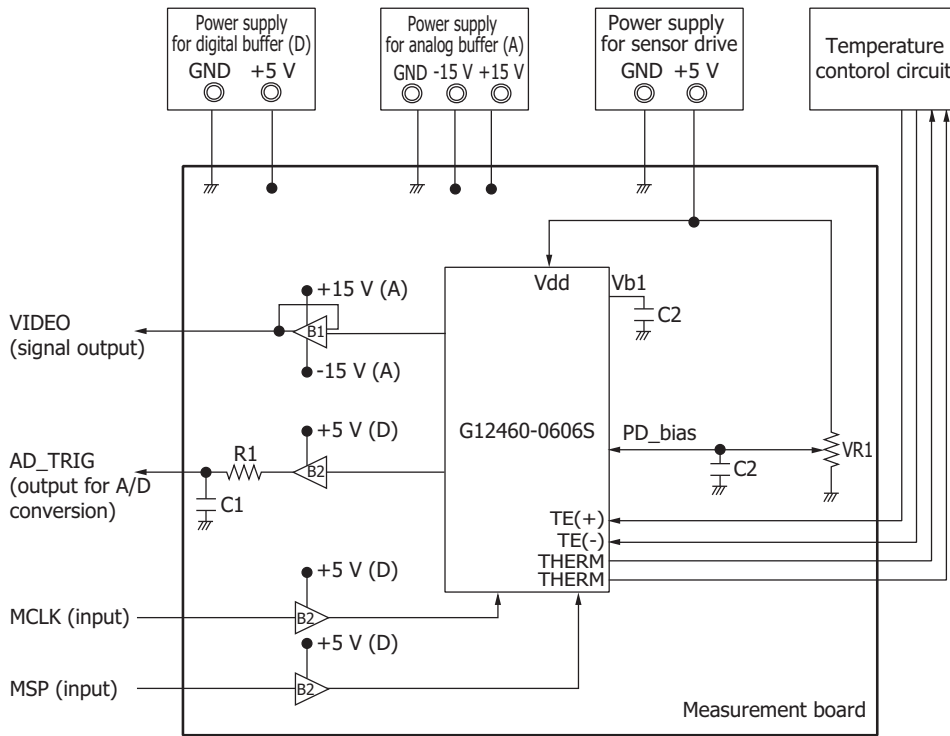

(Reference) Parameter values

Symbol	Value
R1	10 Ω
VR1	10 kΩ
C1	330 pF
C2	0.1 μF

(Reference) Buffer

Symbol	Type no.
B1	AD847
B2	TC74VHCT541

KMIRC0075EA

Timing chart

The video output from a single pixel is equal to 8 MCLK (master clock) pulses. The MSP (master start pulse) is a signal for setting the integration time, so making the low (0 V) period of the MSP longer will extend the integration time. The MSP also functions as a signal that triggers each control signal to perform frame scan. When the MSP goes from low (0 V) to high (5 V), each control signal starts on the falling edge of the MCLK and frame scan is performed during the high period of the MSP.

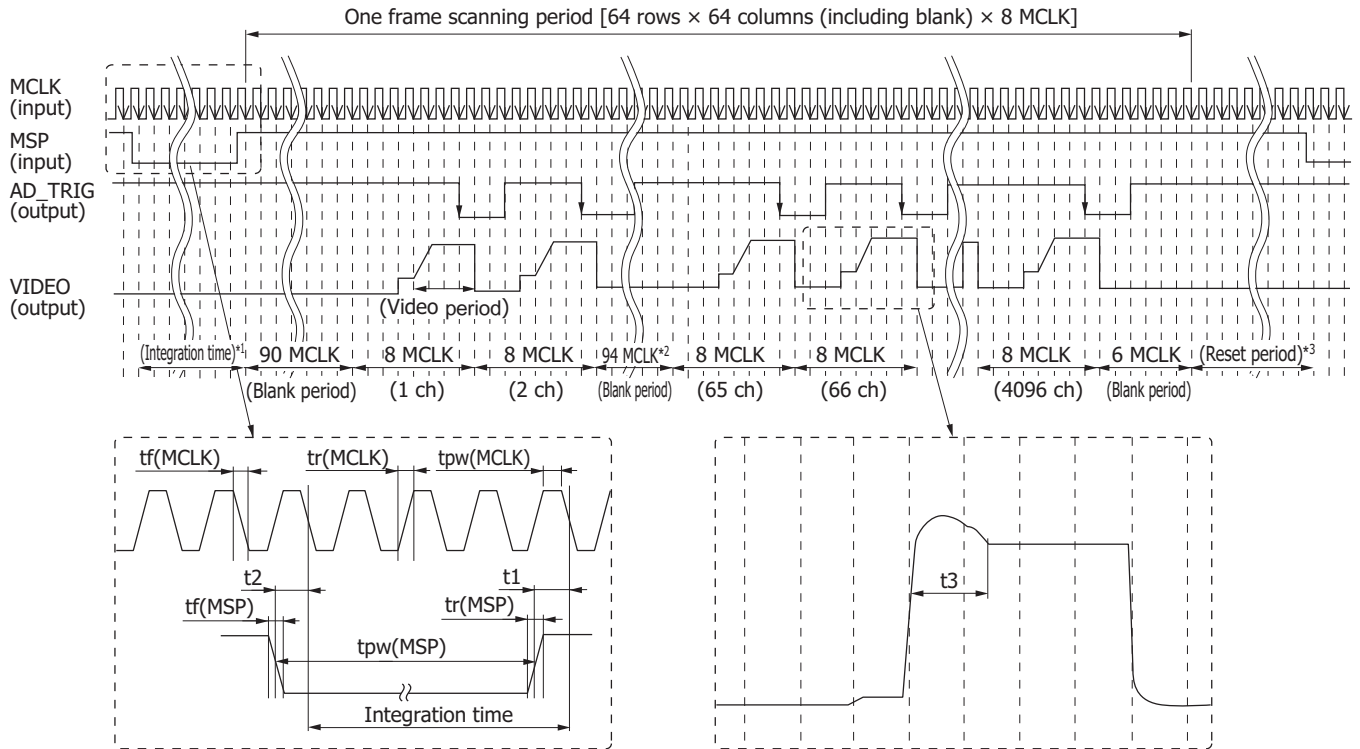

*1: A minimum number of MCLK of integration time is 40 MCLK.
 *2: There are blanks of 94 MCLK between each row.
 *3: A minimum number of MCLK of reset period is 200 MCLK.

KMIRC0044EC

Parameter	Symbol	Min.	Typ.	Max.	Unit
Clock pulse voltage	High	$V_{dd} - 0.5$	V_{dd}	$V_{dd} + 0.5$	V
	Low	0	0	0.5	V
Clock pulse rise/fall times	$t_r(\text{MCLK})$	0	10	12	ns
	$t_f(\text{MCLK})$				
Clock pulse width	$t_{pw}(\text{MCLK})$	10	-	-	ns
Start pulse voltage	High	$V_{dd} - 0.5$	V_{dd}	$V_{dd} + 0.5$	V
	Low	0	0	0.5	V
Start pulse rise/fall times	$t_r(\text{MSP})$	0	10	12	ns
	$t_f(\text{MSP})$				
Start pulse width ^{*3}	$t_{pw}(\text{MSP})$	0.001	-	2	ms
Start (rise) timing ^{*4}	t1	10	-	-	ns
Start (fall) timing ^{*4}	t2	10	-	-	ns
Output setting time	t3	-	-	50	ns

*3: Integration time max.=2 ms

*4: Setting these timings shorter than minimum value may delay the operation by one MCLK pulse and cause malfunction.

Spectral response

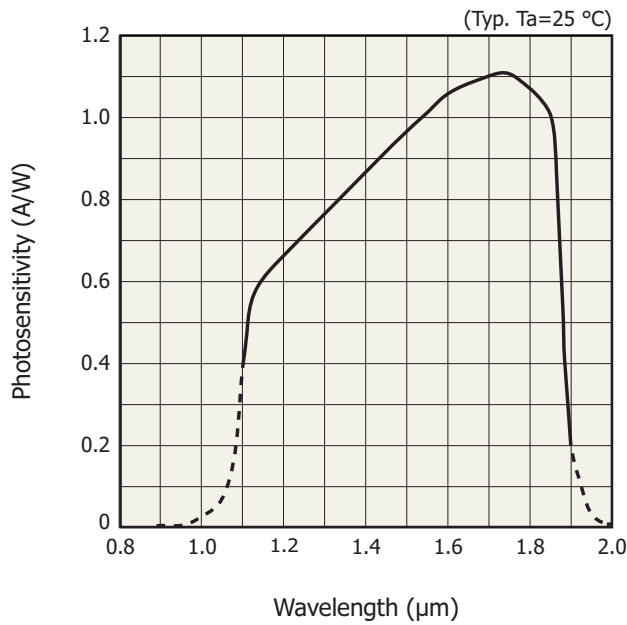

KMIRB0078EA

Photosensitivity temperature characteristics

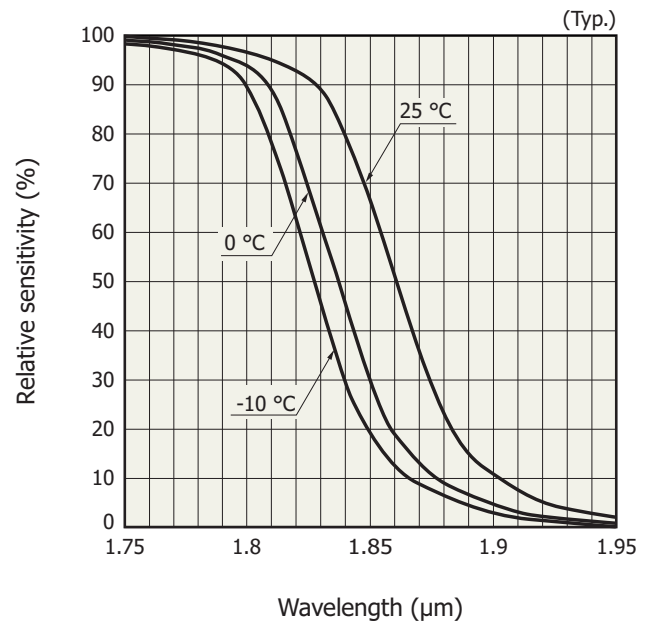

KMIRB0087EA

Thermistor temperature characteristics

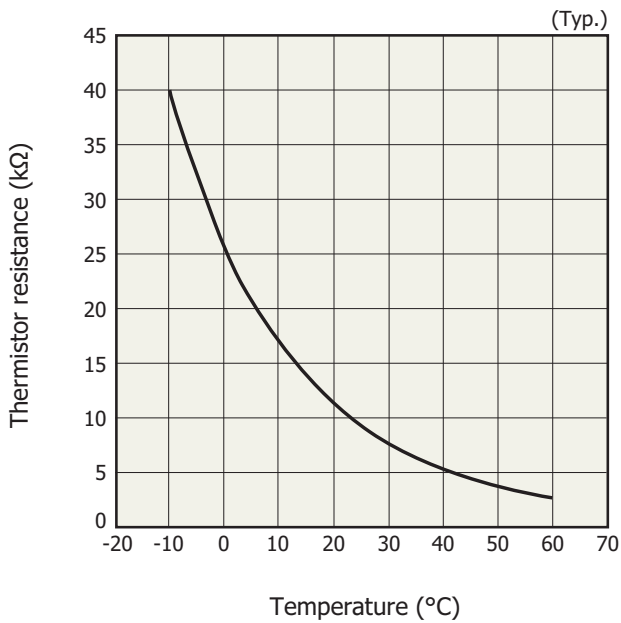

KMIRB0067EA

Cooling characteristics (TE-cooler)

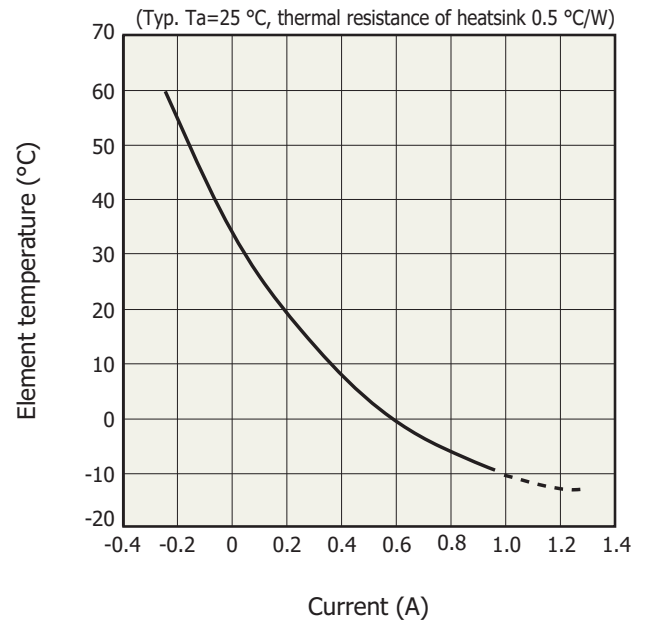

KMIRB0054ED

There is the following relation between the thermistor resistance and temperature (°C).

$$R1 = R2 \times \exp B \left\{ \frac{1}{T1 + 273.15} - \frac{1}{T2 + 273.15} \right\}$$

R1: Resistance at T1 (°C)

R2: Resistance at T2 (°C)

B: B constant (B=3410 K ± 2%)

Thermistor resistance=9 kΩ (at 25 °C)

Current vs. voltage (TE-cooler)

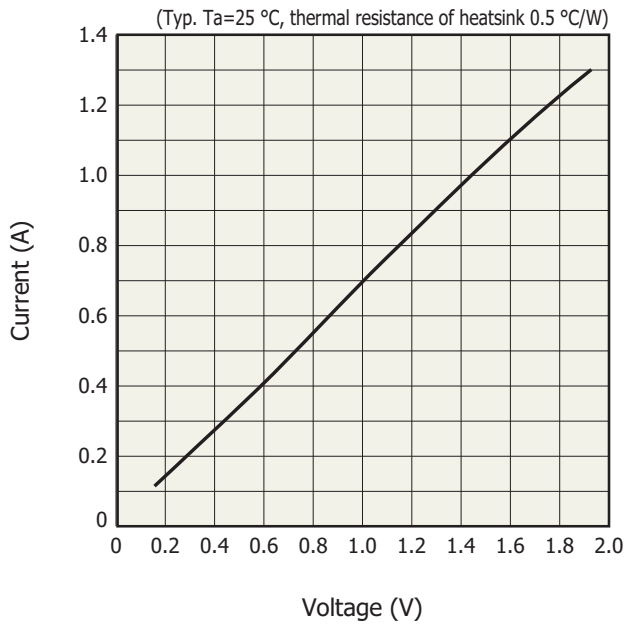

KMIRB0055ED

Dimensional outline (unit: mm)

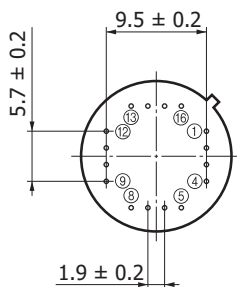
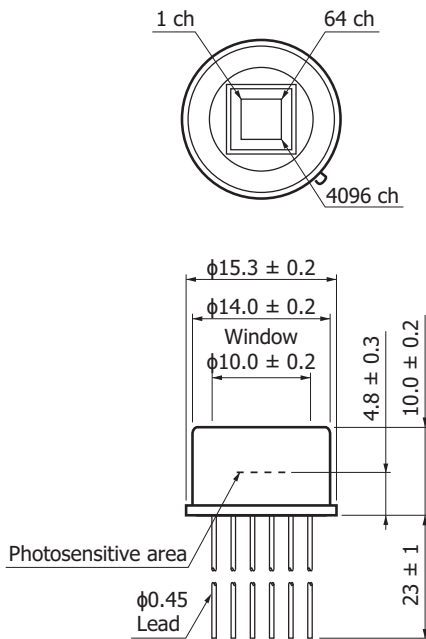

Position accuracy of photosensitive area center with respect to cap center
 $-0.5 \leq X \leq +0.5$
 $-0.5 \leq Y \leq +0.5$

Package material: kovar metal
 Window material: borosilicate glass with anti-reflective coating
 Window sealing method: hermetic

KMIRA0021EB

Pin connections

Pin no.	Name	Input/Output	Function	Remark
1	Vss	Input	0 V ground	0 V
2	Vdd	Input	+5 V supply voltage	5 V
3	MCLK	Input	Clock pulse for timing generator	Falling synchronous pulse
4	AD_TRIG	Output	Signal for A/D sampling	Falling synchronous pulse
5	MSP	Input	Clock pulse for flame scan start	
6	NC	-	-	
7	NC	-	-	
8	Vdd	Input	+5 V supply voltage	5 V
9	PD_bias	Input	Photodiode bias voltage	4.5 V
10	Vb1	Output	Pixel bias voltage	1.27 V
11	NC	-	-	
12	VIDEO	Output	Video output	1.2 to 3.2 V
13	TE (-)	Input	TE-cooler (-)	
14	THERM	Output	Thermistor	
15	THERM	Output	Thermistor	
16	TE (+)	Input	TE-cooler (+)	

* Do not connect anything to the NC terminals.

Note: Connect a bypass capacitor of 0.1 μ F to the Vb1 terminal.

Precautions

(1) Electrostatic countermeasures

This device has a built-in protection circuit against static electrical charges. However, to prevent destroying the device with electrostatic charges, take countermeasures such as grounding yourself, the workbench and tools to prevent static discharges. Also protect this device from surge voltages which might be caused by peripheral equipment.

(2) Incident window

If dust or dirt gets on the light incident window, it will show up as black blemishes on the image. When cleaning, avoid rubbing the window surface with dry cloth or dry cotton swab, since doing so may generate static electricity. Use soft cloth, paper or a cotton swab moistened with alcohol to wipe dust and dirt off the window surface. Then blow compressed air onto the window surface so that no spot or stain remains.

(3) Soldering

To prevent damaging the device during soldering, take precautions to prevent excessive soldering temperatures and times. Soldering should be performed within 5 seconds at a soldering temperature below 260 °C.

(4) Operating and storage environments

Handle the device within the temperature range specified in the absolute maximum ratings. Operating or storing the device at an excessively high temperature and humidity may cause variations in performance characteristics and must be avoided.

Related information

www.hamamatsu.com/sp/ssd/doc_en.html

■ Precautions

- Disclaimer
- Image sensors

Information described in this material is current as of May, 2015.

Product specifications are subject to change without prior notice due to improvements or other reasons. This document has been carefully prepared and the information contained is believed to be accurate. In rare cases, however, there may be inaccuracies such as text errors. Before using these products, always contact us for the delivery specification sheet to check the latest specifications.

The product warranty is valid for one year after delivery and is limited to product repair or replacement for defects discovered and reported to us within that one year period. However, even if within the warranty period we accept absolutely no liability for any loss caused by natural disasters or improper product use. Copying or reprinting the contents described in this material in whole or in part is prohibited without our prior permission.

HAMAMATSU

www.hamamatsu.com

HAMAMATSU PHOTONICS K.K., Solid State Division

1126-1 Ichino-cho, Higashi-ku, Hamamatsu City, 435-8558 Japan, Telephone: (81) 53-434-3311, Fax: (81) 53-434-5184

U.S.A.: Hamamatsu Corporation: 360 Foothill Road, Bridgewater, N.J. 08807, U.S.A., Telephone: (1) 908-231-0960, Fax: (1) 908-231-1218

Germany: Hamamatsu Photonics Deutschland GmbH: Arzbergerstr. 10, D-82211 Herrsching am Ammersee, Germany, Telephone: (49) 8152-375-0, Fax: (49) 8152-265-8

France: Hamamatsu Photonics France S.A.R.L.: 19, Rue du Saule Trapu, Parc du Moulin de Massy, 91882 Massy Cedex, France, Telephone: 33-(1) 69 53 71 00, Fax: 33-(1) 69 53 71 10

United Kingdom: Hamamatsu Photonics UK Limited: 2 Howard Court, 10 Tewin Road, Welwyn Garden City, Hertfordshire AL7 1BW, United Kingdom, Telephone: (44) 1707-294888, Fax: (44) 1707-325777

North Europe: Hamamatsu Photonics Norden AB: Torshamnsgatan 35 16440 Kista, Sweden, Telephone: (46) 8-509-031-00, Fax: (46) 8-509-031-01

Italy: Hamamatsu Photonics Italia S.r.l.: Strada della Moia, 1 int. 6, 20020 Arese (Milano), Italy, Telephone: (39) 02-93581733, Fax: (39) 02-93581741

China: Hamamatsu Photonics (China) Co., Ltd.: B1201, Jiaming Center, No.27 Dongsanhuan Beilu, Chaoyang District, Beijing 100020, China, Telephone: (86) 10-6586-6006, Fax: (86) 10-6586-2866