

# TDI camera C10000-801



The C10000-801 TDI camera is useful for a wide range of imaging applications requiring high speed operation with high sensitivity simultaneously. TDI is a special image acquisition method that has been used extensively in machine vision applications for industrial inspection. TDI imaging is appropriate for applications where it is desired to record a linear process over time, or where the aspect ratio of the subject being imaged is significantly asymmetric. TDI is particularly useful for low light level scanning applications for which a typical line scan camera can not make a useful image. Also, frame readout mode is available for easy focusing.

## FEATURES

- **High resolution / high sensitivity**  
(Horizontal spatial resolution with 128(V) TDI stages)  
▪ 2048(H) × 128 (V) , 4 TAP
- **Line rate up to 50 kHz**
- High speed imaging combined with high sensitivity and low noise
- Great spectral response for UV-NIR with back thinned CCD
- 100× anti-blooming with lateral overflow drain
- Dynamic range of 1600 : 1
- 12 bit / 8 bit selectable A/D converter
- Bidirectional scanning operation
- Frame readout mode for easy focusing
- Real time shading correction with internal DSP

## APPLICATIONS

- High speed imaging for low light applications  
i.e. fluorescence imaging
- Electronics manufacturing and inspection
- Semiconductor inspection
- High speed scanning for a large size sample  
i.e. flat panel displays

## OPERATING PRINCIPLE OF TDI

### TDI (Time Delay Integration):

Time Delay Integration is a scanning technology in which a frame transfer device produces a continuous video image of a moving object by means of a stack of linear arrays aligned with and synchronized to the motion of the object to be imaged in such a way that, as the image moves from one line to the next, the integrated charge moves along with it, providing higher resolution at lower light levels than is possible with a line-scan camera.

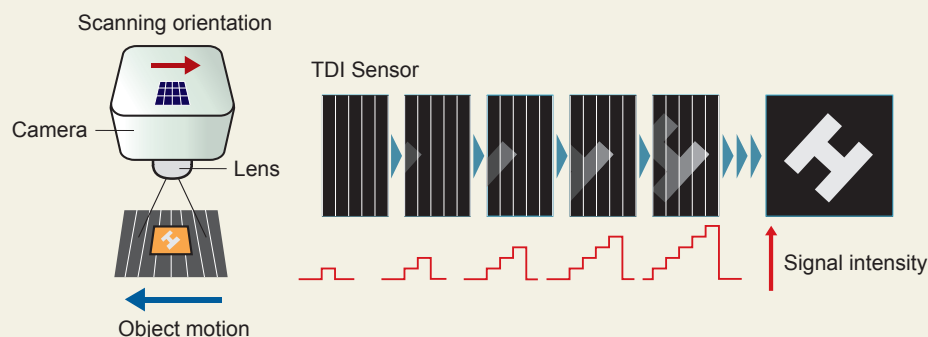

## SPECIFICATIONS

Type number	C10000-801
Device structure	Back-thinned type
Effective number of pixels	2048 (H) × 128 (V)
Cell size	12 μm (H) × 12 μm (V)
Effective area	24.58 mm (H) × 1.536 mm (V)
Lens mount	F-mount
Camera Link connector	Mini-Camera Link (SDR) × 1
Readout mode	TDI readout mode / frame readout mode* <sup>1</sup>
TDI transfer direction	Bidirectional transfer
TDI output channel	4 TAP (512 × 128)
Anti-blooming	Lateral overflow drain (100×)
TDI pixel clock rate	30 MHz
TDI line rate	0.457 kHz to 50 kHz
TDI line rate control	Internal setting by serial command* <sup>2</sup> / External trigger
Full-well capacity (typ.)	80 000 electrons
Readout noise (rms typ.)	50 electrons
Dynamic range	1600 : 1
Binning	2 × 2, 4 × 4
Analog enhancement gain	1 time to 5 times (16 steps)
Digital output	12 bit / 8 bit * <sup>3</sup>
Image processing	Real-time shading correction / Back ground subtraction
Interface	Camera Link base configuration
Camera control	Serial control in Camera Link
Camera output clock	60 MHz
Camera output channel	2 TAP (1024 × 128)
Power requirements	AC100 V to AC240 V, 50 Hz/60 Hz
Power consumption	Approx. 55 VA
Ambient operating temperature	0 °C to +40 °C
Ambient operating humidity	30 % to 70 % (with no condensation)
Ambient storage temperature	-10 °C to +50 °C

\*1 Frame readout mode is useful for easy focusing, but it is not suitable for measurement. Please consult with our sales office for details.

\*2 Internal TDI line rate is set by 33 ns step.

\*3 Selectable by serial command

## DIMENSIONAL OUTLINES (Unit : mm)

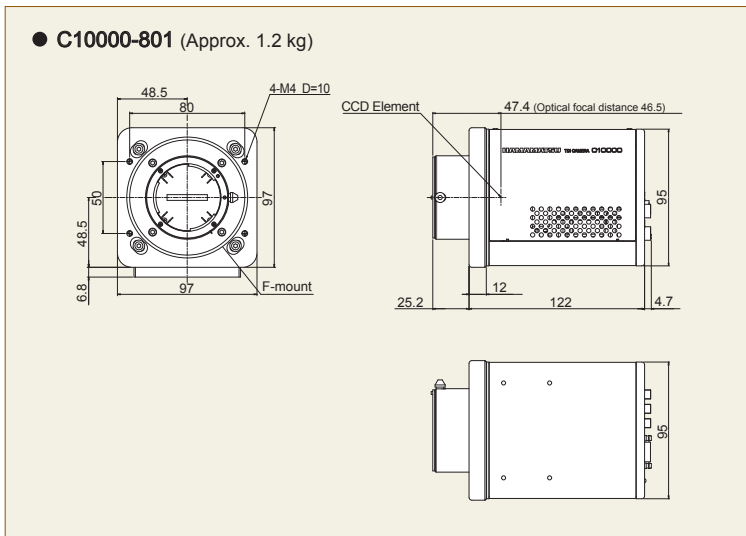

- Product and software package names noted in this documentation are trademarks or registered trademarks of their respective manufacturers.
  - Subject to local technical requirements and regulations, availability of products included in this promotional material may vary. Please consult your local sales representative.
  - Information furnished by HAMAMATSU is believed to be reliable. However, no responsibility is assumed for possible inaccuracies or omissions.
- Specifications and external appearance are subject to change without notice.

© 2017 Hamamatsu Photonics K.K.

## HAMAMATSU PHOTONICS K.K. [www.hamamatsu.com](http://www.hamamatsu.com)

### HAMAMATSU PHOTONICS K.K., Systems Division

812 Joko-cho, Higashi-ku, Hamamatsu City, 431-3196, Japan, Telephone: (81)53-431-0124, Fax: (81)53-435-1574, E-mail: [export@sys.hpk.co.jp](mailto:export@sys.hpk.co.jp)

U.S.A.: Hamamatsu Corporation, 360 Foothill Road, Bridgewater, NJ 08807, U.S.A., Telephone: (1)908-231-0960, Fax: (1)908-231-1218 E-mail: [usa@hamamatsu.com](mailto:usa@hamamatsu.com)

Germany: Hamamatsu Photonics Deutschland GmbH, Arzbergerstr. 10, D-82211 Herrsching am Ammersee, Germany, Telephone: (49)8152-375-0, Fax: (49)8152-265-8 E-mail: [info@hamamatsu.de](mailto:info@hamamatsu.de)

France: Hamamatsu Photonics France S.A.R.L., 19, Rue du Saule Trapu, Parc du Moulin de Massy, 91882 Massy Cedex, France, Telephone: (33)1 69 53 71 00, Fax: (33)1 69 53 71 10 E-mail: [infos@hamamatsu.fr](mailto:infos@hamamatsu.fr)

United Kingdom: Hamamatsu Photonics UK Limited, 2 Howard Court, 10 Tewin Road, Welwyn Garden City, Hertfordshire AL7 1BW, UK, Telephone: (44)1707-294888, Fax: (44)1707-325777 E-mail: [info@hamamatsu.co.uk](mailto:info@hamamatsu.co.uk)

North Europe: Hamamatsu Photonics Norden AB, Torshamnsgatan 35 16440 Kista, Sweden, Telephone: (46)8-509-031-00, Fax: (46)8-509-031-01 E-mail: [info@hamamatsu.se](mailto:info@hamamatsu.se)

Italy: Hamamatsu Photonics Italia S.r.l., Strada della Moia, 1 int. 6, 20020 Arese (Milano), Italy, Telephone: (39)02-935-81-733, Fax: (39)02-935-81-741 E-mail: [info@hamamatsu.it](mailto:info@hamamatsu.it)

China: Hamamatsu Photonics (China) Co., Ltd., 1201 Tower B, Jiamei Center, 27 Dongsanhuan Beilu, Chaoyang District, 100020 Beijing, China, Telephone: (86)10-6586-6006, Fax: (86)10-6586-2866 E-mail: [hpc@hamamatsu.com.cn](mailto:hpc@hamamatsu.com.cn)

Taiwan: Hamamatsu Photonics Taiwan Co., Ltd., 8F-3, No.158, Section2, Gongdao 5th Road, East District, Hsinchu, 300, Taiwan R.O.C. Telephone: (886)03-659-0080, Fax: (886)07-811-7238 E-mail: [info@tw.hpk.co.jp](mailto:info@tw.hpk.co.jp)

## SPECTRAL RESPONSE

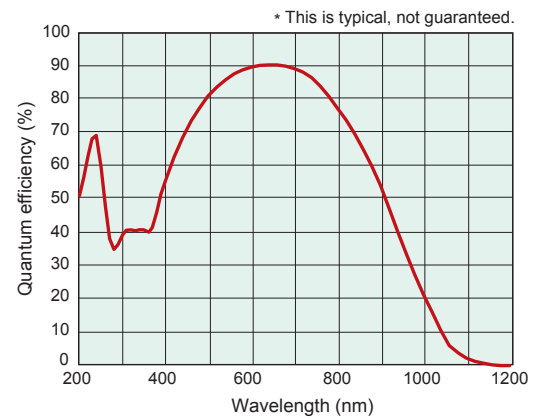

\* Without sapphire window. With the sapphire window, the spectral response is decreased due to the transmittance characteristics of the window.

## TDI SENSOR STRUCTURE

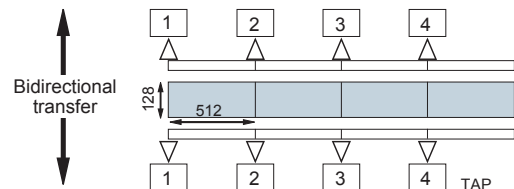

## OPTIONS

- External trigger cable SMA-BNC 5 m : A12106-05
- External trigger cable SMA-SMA 5 m : A12107-05
- Camera Link cable SDR-MDR 5 m : A10514-05
- Frame grabber board Camera Link : M9982-09