

# iPHEMOS™-MPX

Inverted emission microscope C10506-07-06

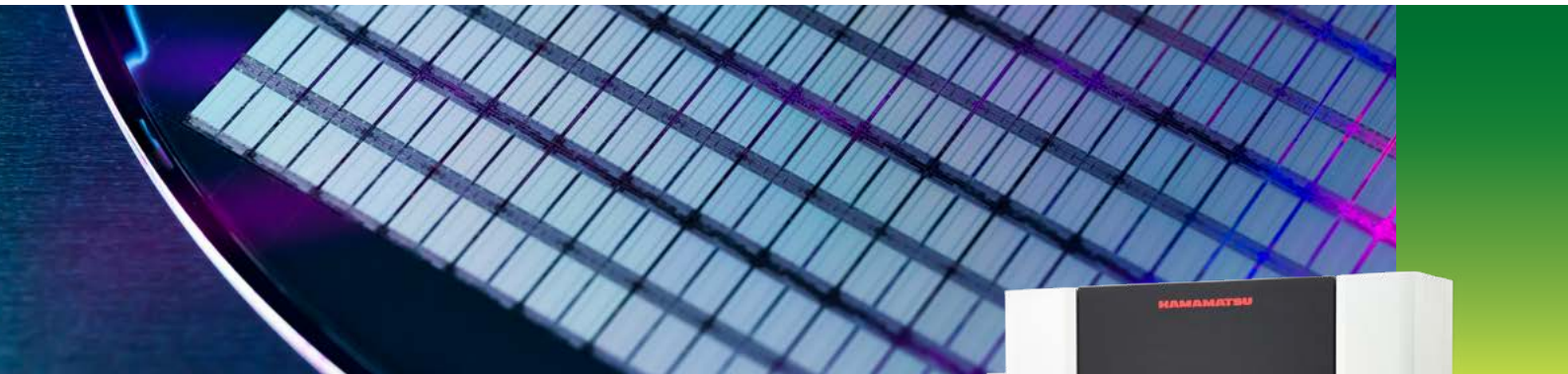

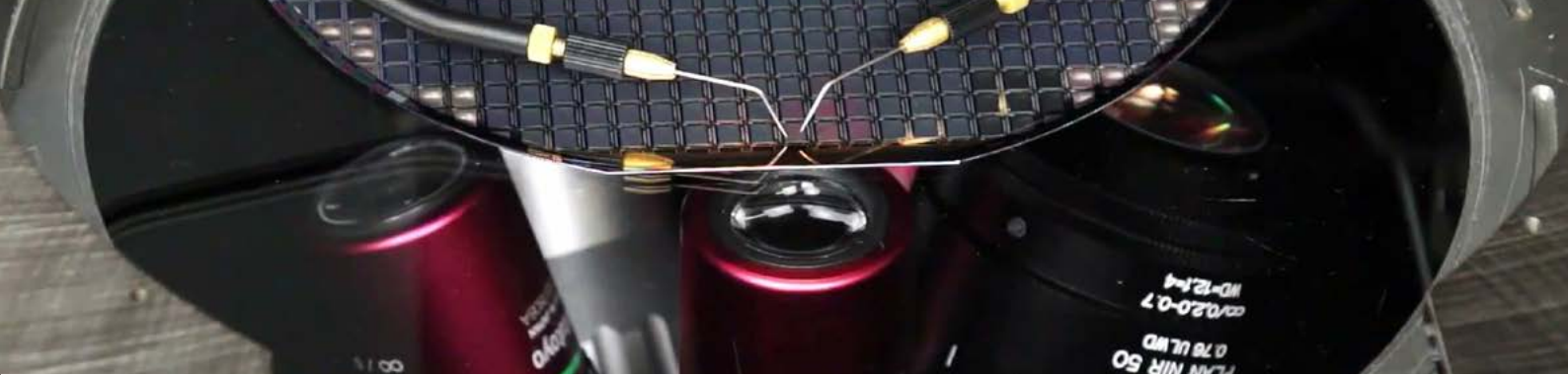

# iPHEMOS™-MPX

The iPHEMOS™-MPX is a high-resolution inverted emission microscope that pinpoints failure locations in semiconductor devices by detecting the weak light emissions and heat emissions caused by defects.

The signal detection from bottom side facilitates the use of probing and probe card to the wafer surface, and the sample setting can be performed smoothly.

The platform, possible to mount multiple detectors and lasers, enables the selection of the optimum detector for performing various analysis methods such as light emission and heat generation analysis, IR-OBIRCH analysis, and others; moreover, letting dynamic analysis perform efficiently by tester connection.

Support for measurement from a single chip to a wafer by mounting a 300 mm wafer prober. Multi-pin needle contact by probe card and sample observation on PC board are available.



## Features

- **Two ultra-high sensitivity cameras are mountable**

Coverage of different detection wavelength ranges for emission analysis and thermal analysis allows easy selection of an analysis technique that matches the sample and failure mode.

- **Up to 7 light sources for OBIRCH, DALIS, EOP and laser marker are mountable**

- **High sensitivity macro lens and up to 10 lenses suitable for each detector sensitivity wavelength**

- **High accuracy stage designed for advanced devices**

Working range of the optical stage

X	60 mm
Y	60 mm
Z	20 mm

\* Working range might be narrower than these values due to the prober being used and interference with the sample stage or mounting of a NanoLens.

## Basic display functions

### Superimposed display/contrast enhancement function

The iPHEMOS™-MPX superimposes the emission image on a high-resolution pattern image to localize defect points quickly. The contrast enhancement function makes an image clearer and more detailed.

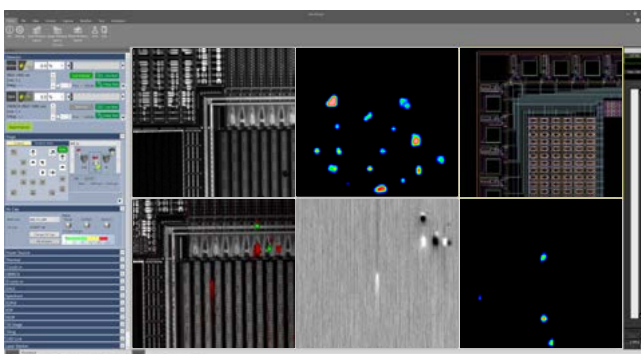

\* The actual display may differ depending on your software version, environment, etc.

### ■ Display function

- **Annotations**  
Comments, arrows, and other indicators can be displayed on an image at any locations desired.
- **Scale display**  
The scale width can be displayed on the image using segments.
- **Grid display**  
Vertical and horizontal grid lines can be displayed on the image.
- **Thumbnail display**  
Images can be stored and recalled as thumbnails, and image information such as stage coordinates can be displayed.
- **Split screen display**  
Pattern images, emission images, superimposed images, and reference images can be displayed in a 6-window screen at once.

## Camera

### InGaAs camera for photo emission

NIR

The low operating voltage that accompanies the miniaturization of semiconductor devices leads to a decrease in the intensity of light emitted from the failure location as well as to longer wavelengths. A detector with high sensitivity to near-infrared light of 900 nm or longer is essential for detecting such faint light emission.

The InGaAs camera series offers high sensitivity (high quantum efficiency) in the near-infrared wavelength range and is effective for low-voltage drive IC measurement and weak light analysis from the device's bottom side. Combined with a laser scan system, it also enables high-resolution and high-sensitivity analysis.

#### InGaAs camera

The InGaAs camera has high sensitivity in the near-infrared wavelength range. Peltier cooling or LN2 cooling can be selected for the camera cooling system.

#### Solid Cold InGaAs camera

This is a camera with high sensitivity in the near-infrared wavelength range. It operates without contact using a linear motor (magnetic force), which allows for the movement of the cylinder and piston with minimal mechanical wear, resulting in a reliable structure. It is possible to run the unit continuously for 24 hours, which was difficult with the LN2 cooling type.

#### Application

- Bottom side analysis of Si semiconductor devices
- Junction failure of low-voltage drive devices

### ThermoDynamic camera for thermal emission

MIR

With miniaturization and low-voltage drive of semiconductor devices, infrared light originating from heat generated at failure locations is becoming increasingly weak and difficult to detect. The ThermoDynamic camera has high sensitivity in the mid-infrared wavelength range and can capture such weak thermal signals with high sensitivity.

#### Application

- Short-circuits in metallic layers and wiring
- Abnormal resistance at contact holes
- Insulation leakage

### Thermal lock-in measurement

The lock-in measurement method deducts noise by synchronizing the timing of power supply to a device and image capture. With this method, a thermal lock-in unit can provide high quality images even for low voltage devices.

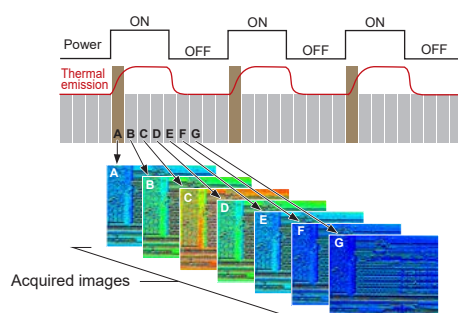

#### Comparison images

\* Objective lens: 8x, Bias: 1.7 V, 14.5 mA

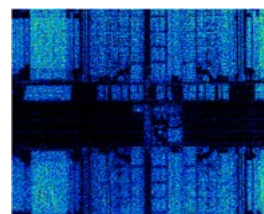

No lock-in

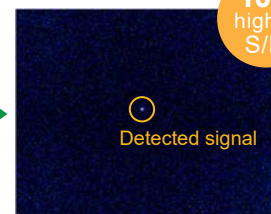

Lock-in

10x  
higher  
S/N

High S/N is achieved by acquiring signals at a specific frequency and eliminating signals at other frequencies as noise.

# Laser

## Laser scan system

The laser scan system obtains clear, high-contrast pattern images by scanning the bottom side of a chip with the infrared laser (1.3 μm and/or 1.1 μm). Within 1 second, a pattern image can be acquired. By the flexible scan in 6 directions, it is possible to scan a device from different directions without rotating it. Scanning in parallel with a metal line makes OBIRCH image clearer. The function is also useful in OBIRCH analysis using a digital lock-in and dynamic analysis by laser stimulation.

### Standard function

- **Dual scan**  
Obtain a pattern image and an IR-OBIRCH image simultaneously
- **Flexible scan**  
Normal scan (2048 × 2048, 1024 × 1024, 512 × 512, 256 × 256), Area zoom, Slit H, Slit V, Area Flexible, Mask, Point scan, Scan direction changeable (0°, 45°, 90°, 180°, 225°, 270°)

## IR-OBIRCH analysis

IR-OBIRCH (InfraRed Optical Beam Induced Resistance CHange) analysis detects current alteration caused by leakage current paths and contact area resistance failure in devices by irradiating an infrared laser.

### Features

- High-resolution, high-contrast reflection pattern images
- Bottom side observation capable (using a 1.3 μm wavelength laser)
- Non-OBIC signal generated in the semiconductor field by Si material since using an infrared laser
- Possible to measure at four quadrants of voltage/current

### Principle

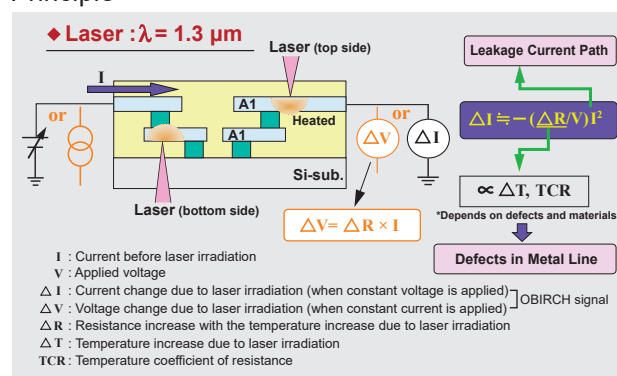

The OBIRCH amp can work for devices, which need to apply four quadrants of voltage/current. V1 mode, I1 mode, V2 mode, and V3 mode are selectable via software.

	V1 mode	I1 mode	V2 mode	V3 mode
Voltage range	-10 V to +10 V		-25 V to +25 V	-3 V to +3 V
Current range	-100 mA to +100 mA		-1 mA to +1 mA *1	-1 μA to +1 μA
Detectability	1 nA *2	1 μV *3	3 pA *2	1 pA *2

\*1 Specifications may vary depending on the options used.

\*2 Minimum detectable pulse signal input into the amplifier

\*3 Calculated value

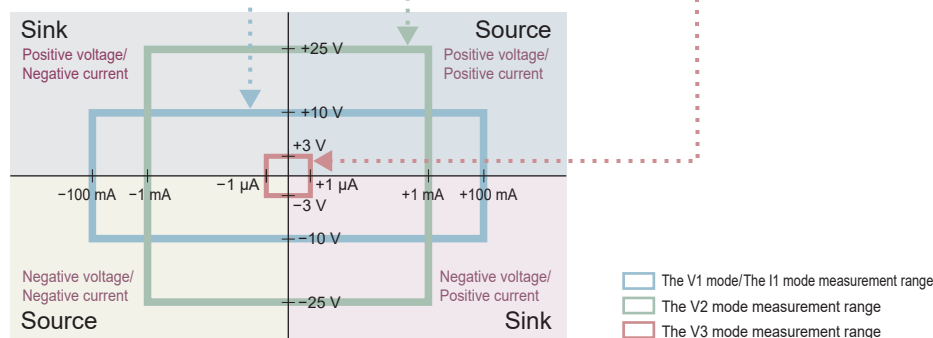

**Digital lock-in**

Digital lock-in is a function of OBIRCH analysis that boosts detection sensitivity by converting the data from one pixel into multiple data using software lock-in processing.

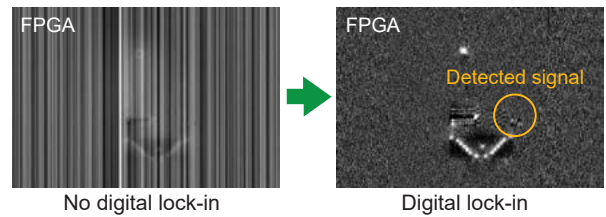

**Analysis using the current detection head**

A current detection head can be used to measure devices that require higher voltage (Max. 3 kV) or higher current (Max. 6.3 A) than the range of standard OBIRCH amp.

**DALS**

Due to high integration and increased performance of LSI, functional failure analysis under LSI tester connection becomes very important. DALS (Dynamic Analysis by Laser Stimulation) is a new method to analyze device operation conditions by means of laser radiation. Stimulate a device with a 1.3 μm laser while operating it with test patterns by LSI tester. Then device operation status (pass/fail) changes due to heat generated by the laser. The pass/fail signal change is expressed as an image that indicates the point causing timing delay, marginal defect, etc.

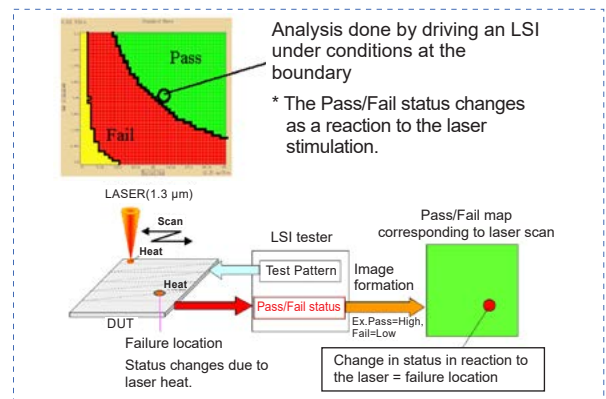

Concept of the analysis of a failed device by utilizing the "drive voltage – operating frequency" characteristics

**EO probing analysis**

In EO (Electro Optical) probing analysis, incoherent light (1.3 μm and/or 1064 nm) is irradiated to the bottom side of a semiconductor device and the reflected light is measured to check whether the semiconductor device is operating normally on the basis of the transistor operating frequency and its change over time.

EO probing analysis includes an EOP (Electro Optical Probing) function that measures the operating voltage at high speeds and an EOFM (Electro Optical Frequency Mapping) function that captures images of sections operating at a specific frequency. When used with a NanoLens, measurements can be made with higher resolution and sensitivity.

**EOP Function**

This function acquires switching timing of a specific transistor rapidly by high speed sampling. As an extended analysis of emission and OBIRCH, the EOP function improves accuracy of failure point localization, enabling a much smoother follow-up physical analysis.

Bandwidth	1 kHz to 7 GHz
-----------	----------------

**EOFM Function**

This function measures transistors switching at a specific frequency and images them. The reflected light from a drain has the power spectrum distribution. The EOFM picks up the intensity of signal under certain frequency from the distribution and visualize it as an image. By operating transistors in a specific region under certain frequency, it is possible to observe if the circuits are correctly switching or not. 4 images can be acquired simultaneously. (patented)

Bandwidth	1 kHz to 1.5 GHz
-----------	------------------

**Principle**

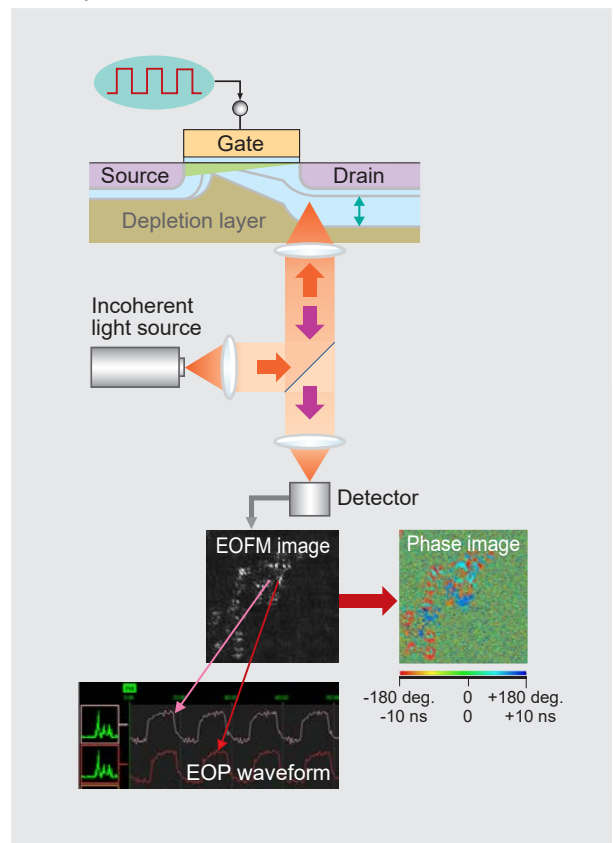

## Lens

### Lens selection

Up to 10 types of objective lenses can be mounted on the motorized turret. The macro lens for emission analysis can be installed on the system.

#### Objective lens

Product name	Product number	N.A.	WD (mm)	Analysis
Objective lens 1× for OBIRCH	A7649-01	0.03	20	OBIRCH
Objective lens 2× IR coat	A8009	0.055	34	Emission/OBIRCH
Objective lens NIR 5×	A11315-01	0.14	37.5	Emission/OBIRCH
Objective lens NIR 20×	A11315-03	0.4	20	Emission/OBIRCH
Objective lens PEIR Plan Apo 20× 2000	A11315-21	0.6	10	Emission/OBIRCH
Objective lens PEIR Plan Apo 50× 2000	A11315-22	0.7	10	Emission/OBIRCH
High NA objective lens 50× for IR-OBIRCH	A8018	0.76	12	OBIRCH
Objective lens NIR 100×	A11315-05	0.5	12	Emission/OBIRCH
Objective lens NIR-UHR 100×	A11315-09	0.7	10	Emission/OBIRCH
Objective lens MWIR 0.8×	A10159-02	0.13	22	Thermal emission
Objective lens MWIR 4×	A10159-03	0.52	25	Thermal emission
Objective lens MWIR 8×	A10159-06	0.75	15	Thermal emission

#### Macro lens

Product name	Product number	N.A.	WD (mm)	Analysis
Macro lens 1.35× for iPHEMOS™	A13573-01	0.38	15	Emission

### Macro lens

The 1.35× macro lens has a high numerical aperture (N.A.) of 0.38 for high sensitivity capture of weak light emissions. The software smoothly switches from macro to micro observation that uses an objective lens.



### NanoLens

For bottom side observation, near-infrared light is used to penetrate the Si layer. On the other hand, optical resolution gets worse at longer wavelengths. The NanoLens (a solid immersion lens) is a hemispherical lens that touches the LSI substrate and utilizes the index of refraction of silicon to increase the numerical aperture, which improves spatial resolution and convergence efficiency. By setting the NanoLens-WR (N.A. 3.1) on a point to observe on the bottom side of a device, it is possible to perform analysis at a sub-micron level of spatial resolution in a short period of time with greatly improved accuracy. And the Thermal NanoLens (N.A. 2.6) is applicable to thermal analysis.



## External connection

### Connecting to an LSI tester

As devices become more complicated, there is increased demand for analysis under an LSI tester connection to find a failure occurring at a specific point while a device is functioning. It is possible to connect an LSI tester with the iPHEMOS™-MPX by a short cable and using a probe card adapter specifically designed for the analysis under the iPHEMOS™-MPX optics.

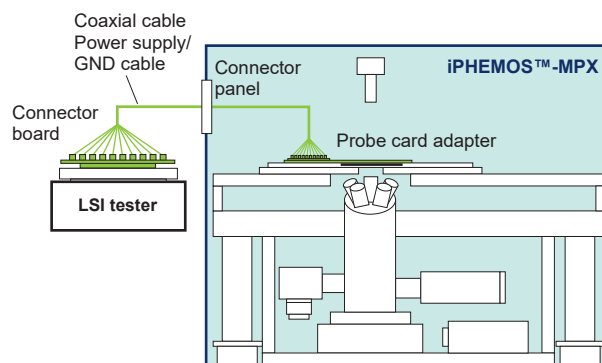

### Connecting to a CAD navigation system

When performing failure analysis of complicated LSI chips on a large scale, it is possible to connect through a network (TCP/IP) and CAD navigation software. This helps the subsequent investigation of problem locations. By superimposing an area where a problem has been detected, or an image, over the layout diagram, it is possible to identify defective points.

## Specification

### Dimensions / Weight

Main unit	1654 mm (W) × 1541 mm (H) × 1200 mm (D) *1 Approx. 1100 kg *2	
System rack	880 mm (W) × 1841.5 mm (H) × 715 mm (D) *1 Approx. 300 kg	
Operation desk *3	<ul style="list-style-type: none"> <li>● C16216-01 Operation desk 1000 mm (W) × 700 mm (H) × 800 mm (D) Approx. 39.2 kg</li> </ul>	<ul style="list-style-type: none"> <li>● C16216-02 Operation desk 1480 mm (W) × 700 mm (H) × 800 mm (D) Approx. 48.6 kg</li> </ul>

\*1 Excluding projecting parts

\*2 Including a sample stage

\*3 Option

### Utility

Line voltage	Single phase 200 V to 240 V
Power consumption	Approx. 3300 VA
Vacuum	80 kPa or more
Compressed air *1	0.5 MPa to 0.7 MPa

\*1 Including a regulator

## LASER SAFETY

The iPHEMOS™-MPX is a Class 1 laser product. Hamamatsu Photonics classifies laser diodes, and provides appropriate safety measures and labels according to the classification as required for manufacturers according to IEC 60825-1. When using this product, follow all safety measures according to the IEC.



Description Label (Sample)



Caution Label

- iPHEMOS is a registered trademark of Hamamatsu Photonics K.K. (Japan).
- The product and software package names noted in this brochure are trademarks or registered trademarks of their respective manufacturers.
- Subject to local technical requirements and regulations, availability of products included in this brochure may vary. Please consult your local sales representative.
- The product described in this brochure is designed to meet the written specifications, when used strictly in accordance with all instructions.
- The spectral response specified in this brochure is typical value and not guaranteed.
- The measurement examples in this brochure are not guaranteed.
- Specifications and external appearance are subject to change without notice.

© 2024 Hamamatsu Photonics K.K.

## HAMAMATSU PHOTONICS K.K. [www.hamamatsu.com](http://www.hamamatsu.com)

### Systems Division

812 Joko-cho, Chuo-ku, Hamamatsu City, 431-3196, Japan, Telephone: (81)53-431-0124, Fax: (81)53-433-8031, E-mail: [export@sys.hpk.co.jp](mailto:export@sys.hpk.co.jp)

**U.S.A.:** HAMAMATSU CORPORATION: 360 Foothill Road, Bridgewater, NJ 08807, U.S.A., Telephone: (1)908-231-0960, Fax: (1)908-231-1218

**Germany:** HAMAMATSU PHOTONICS DEUTSCHLAND GMBH: Arzbergerstr. 10, 82211 Herrsching am Ammersee, Germany, Telephone: (49)8152-375-0, Fax: (49)8152-265-8 E-mail: [info@hamamatsu.de](mailto:info@hamamatsu.de)

**France:** HAMAMATSU PHOTONICS FRANCE S.A.R.L.: 19 Rue du Saule Trapu, Parc du Moulin de Massy, 91882 Massy Cedex, France, Telephone: (33)1 69 53 71 00, Fax: (33)1 69 53 71 10 E-mail: [infos@hamamatsu.fr](mailto:infos@hamamatsu.fr)

**United Kingdom:** HAMAMATSU PHOTONICS UK LIMITED: 2 Howard Court, 10 Tewin Road, Welwyn Garden City, Hertfordshire, AL7 1BW, UK, Telephone: (44)1707-294888, Fax: (44)1707-325777 E-mail: [info@hamamatsu.co.uk](mailto:info@hamamatsu.co.uk)

**North Europe:** HAMAMATSU PHOTONICS NORDEN AB: Torshamnsgatan 35 16440 Kista, Sweden, Telephone: (46)8-509 031 00, Fax: (46)8-509 031 01 E-mail: [info@hamamatsu.se](mailto:info@hamamatsu.se)

**Italy:** HAMAMATSU PHOTONICS ITALIA S.R.L.: Strada della Moia, 1 int. 6, 20044 Arese (Milano), Italy, Telephone: (39)02-93 58 17 33, Fax: (39)02-93 58 17 41 E-mail: [info@hamamatsu.it](mailto:info@hamamatsu.it)

**China:** HAMAMATSU PHOTONICS (CHINA) CO., LTD.: 1201 Tower B, Jiaming Center, 27 Dongsanhuan Beilu, Chaoyang District, 100020 Beijing, P.R. China, Telephone: (86)10-6586-6006, Fax: (86)10-6586-2866 E-mail: [hpc@hamamatsu.com.cn](mailto:hpc@hamamatsu.com.cn)

**Taiwan:** HAMAMATSU PHOTONICS TAIWAN CO., LTD.: 13F-1, No.101, Section 2, Gongdao 5th Road, East Dist., Hsinchu City, 300046, Taiwan(R.O.C.), Telephone: (886)3-659-0080, Fax: (886)3-659-0081 E-mail: [info@hamamatsu.com.tw](mailto:info@hamamatsu.com.tw)

Cat. No. SSMS0063E04  
MAY/2024 HPK  
Created in Japan